

# Under cover

## Guidelines for shade planning and design

*With grateful acknowledgement to the  
New South Wales Cancer Council and the  
New South Wales Health Department*



# Under cover

---

## Guidelines for shade planning and design

2000

*With grateful acknowledgement to the  
New South Wales Cancer Council and  
the New South Wales Health Department*



**Cancer  
Society**

Citation:

The following citation should be used when reproducing or quoting any part of this publication:

Greenwood JS, Soulos GP, Thomas ND.

*Under cover: Guidelines for shade planning and design.*

NSW Cancer Council and NSW Health Department Sydney, 1998.

Adapted for New Zealand use by the Cancer Society of New Zealand, 2000

Authors:

JS Greenwood – B.Sc (Arch), B.Arch (Hons), A.R.A.I.A.

Principal, Shelter Strategies Shade Planners and Consultants

GP Soulos and ND Thomas – NSW Cancer Council

Adapted for New Zealand use by Penny St John, John Greenwood and Belinda McLean

Additional copies of this publication are available from your local Cancer Society

This publication is intended as a guide only and should not be relied upon as a definitive or complete statement of the relevant laws or scientific evidence.

© 1998 NSW Health Department

Cancer Society of New Zealand Inc,  
PO Box 12-145, Wellington  
2000

ISBN 0-908933-44-4

# Contents

---

	<b>Acknowledgements</b>	7
	<b>1 About this document</b>	9
	The need for shade	9
	Who is this publication for?	10
	Using this publication	10
<b>Sun facts</b>	<b>2 Sun facts</b>	11
This chapter discusses some important information relating to solar UVR such as direct and indirect UVR, factors that affect UVR levels and the effects of UVR exposure on health. It also explains the sun's daily and annual paths, which is the basis for understanding how to plan effective shade.	The sun and solar ultraviolet radiation	11
	The solar spectrum	11
	Direct and indirect UVR	12
	Factors affecting UVR levels	13
	Health effects of exposure to solar UVR	16
	Earth–sun relationships	17
	Sun angles and their effects on shadow	17
	Daily path	18
	Annual path	18
	Equinox and solstice	20
	Shadow angles	21
<b>Protecting against solar UVR</b>	<b>3 Protecting against solar UVR</b>	23
This chapter focuses on the use of environmental strategies, eg landscaping and/or built structures, to protect against over exposure to UVR. It also suggests methods for creating shaded areas that are comfortable to use year round, for the different climate zones of New Zealand.	Environmental strategies for controlling solar UVR	23
	Control of direct UVR	24
	Control of indirect UVR	25
	Design strategies for the control of indirect UVR	26
	Designing shade for climate and comfort	27
	Shade planning for specific climate zones	27
	Climate characteristics and design considerations	28
	Designing for comfort: general principles	34

<p><b>Providing shade</b></p> <p>This chapter provides information on the range of shade solutions and how to create attractive UVR protective environments. The qualities of commonly used shade materials are discussed.</p>	<p><b>4 Providing shade</b> 37</p> <p style="padding-left: 20px;">Natural shade 38</p> <p style="padding-left: 40px;">Landscape planning and design 39</p> <p style="padding-left: 20px;">Built shade 42</p> <p style="padding-left: 40px;">Permanent systems 42</p> <p style="padding-left: 40px;">Demountable systems 43</p> <p style="padding-left: 40px;">Adjustable systems 43</p> <p style="padding-left: 40px;">Components of built shade 46</p> <p style="padding-left: 40px;">Selecting shade materials 50</p> <p style="padding-left: 40px;">Tension membrane structures 51</p> <p style="padding-left: 40px;">Vandalism 52</p> <p style="padding-left: 40px;">Off-the-shelf structures 52</p> <p style="padding-left: 20px;">Combinations of natural and built shade 53</p>
<p><b>The shade project</b></p> <p>This chapter presents an overview of the major stages of a shade project: planning, design and construction. The key steps to be taken during each of these stages are explained. In particular, a step by step procedure is provided for conducting a Shade Audit of a site.</p> <p>Case studies are presented at the end of the chapter to illustrate aspects of a shade project.</p>	<p><b>5 The shade project</b> 55</p> <p style="padding-left: 20px;">Planning 56</p> <p style="padding-left: 20px;">Design 58</p> <p style="padding-left: 20px;">Construction 60</p> <p style="padding-left: 20px;">The Shade Audit 61</p> <p style="padding-left: 40px;">How to conduct a Shade Audit 61</p> <p style="padding-left: 40px;">How to measure shade 62</p> <p style="padding-left: 40px;">Stage 1: Interviews 63</p> <p style="padding-left: 40px;">Stage 2: Site fieldwork 66</p> <p style="padding-left: 40px;">Stage 3: Assessment 76</p> <p style="padding-left: 40px;">Stage 4: Recommendations 77</p> <p style="padding-left: 40px;">A design brief for your shade project 78</p> <p style="padding-left: 20px;">Shade project case studies 79</p> <p style="padding-left: 40px;">Waikawa Bay School 80</p> <p style="padding-left: 40px;">Balmain Public School 81</p> <p style="padding-left: 40px;">Baradine Multipurpose Courts 82</p> <p style="padding-left: 40px;">Campion College 82</p> <p style="padding-left: 40px;">Springwood High School 83</p> <p style="padding-left: 40px;">Western Suburbs Olympic Pool, Unanderra 84</p>

---

**Site specific considerations**

This chapter provides recommendations and considerations for shade provision at a range of common sites. Planning and design issues for each site are also discussed.

<b>6 Site specific considerations</b>	85
Early childhood services	86
Schools	94
Swimming pools	102
Beaches	108
Sports grounds and facilities	114
Parks and reserves	120
General streetscape	126
Resorts, motels and hotels	132
Outdoor restaurants, cafes and beer gardens	138
The home	142
The workplace	148

---

The **Appendices** contain specific support information.

---

**Appendices****Appendix A**

Risks for public authorities: issues of legal liability – the general situation 153

**Appendix B**

Professional and industry contacts 155

**Appendix C**

Qualities of shade materials 157

**Appendix D**

The Shade Inventory 175

**Appendix E**

Example of a completed Shade Audit 177

---

**References** 186

---

**Glossary** 188



# Acknowledgements

---

Material in this book has been adapted from the Australian version of *Under cover: Guidelines for shade planning and design*. The Cancer Society of New Zealand would like to thank the New South Wales Cancer Council and the New South Wales Health Department for allowing the use of the Australian material. Thanks are also given to the many Australian contributors who are fully acknowledged in the Australian version.

Many references to Australian publications have been retained, because comparable New Zealand publications on the provision of shade are not available. We have also included four case studies of Australian shade projects because these examples of successful, well-planned projects are applicable to New Zealand.

We gratefully acknowledge assistance from the following:

Building Industry Authority

Campion College

KPMG Legal

Ministry of Education

National Institute of Water and Atmospheric Research Ltd (NIWA)

Occupational Safety and Health Service, New Zealand (OSH)

Cancer Society of New Zealand Divisions and Centres

Waikawa Bay Primary School.

---



# 1 About this document

## The need for shade

---

Skin cancer is a major health problem in New Zealand. It is the commonest cancer in this country, with about 20,000 people developing new skin cancers each year.<sup>1</sup> Melanoma rates are among the highest in the world and about 200 New Zealanders die from melanoma each year.

The factors which contribute to these high rates include:

- the intense solar ultraviolet radiation (UVR) levels that characterise the New Zealand environment (most skin cancers are caused by exposure to UVR from the sun)
- large proportion of fair-skinned population
- the outdoor nature of daily life in New Zealand. This means that many activities take place when UVR levels are high
- social values which support the belief that a suntan is healthy and attractive.

Public education campaigns over the last two decades have resulted in an increase in the adoption of personal sun protective behaviours. A comprehensive approach to sun protection, however, includes another vital component. This is the provision and use of UVR protective shade.

Many outdoor facilities and venues in New Zealand currently lack adequate shade. Spectators at local sporting events, picnickers in the local park, school children in the playground or office workers in city plazas at lunchtime may be at risk of excessive UVR exposure due to the lack of shade.

Shade is necessary at outdoor spaces if activities take place there on a regular basis during times of high UVR levels. Most outdoor facilities and venues fit this description, whether they are recreational, educational, commercial or occupational.

As an increasing number of organisations recognise the need for shade, there is also a need to ensure that efforts to provide shade are as effective as possible. It is intended that this publication will contribute to the achievement of such outcomes.

The aims of this publication are to:

- highlight the important contribution shade can make in reducing mortality and morbidity associated with exposure to solar UVR
- explain how to assess the shade needs of a site
- explain how to provide shade that will fall at the right place, at the right time of the day, at the right time of the year
- encourage the provision of shade that is functionally, environmentally and aesthetically sympathetic to surrounding areas.

Consistent with the principles of ecologically sustainable design, this publication seeks to minimise the potential for environmental harm that may result from inappropriate shade design, as well as encourage the 'greening' of both the urban and rural landscape.

---

<sup>1</sup> New Zealand Health Information Service. *Mortality and demographic data 1997*. Wellington, Ministry of Health, 2000.

---

## Who is this publication for?

This publication is written as a comprehensive reference tool for professionals, organisations and individuals involved in shade planning and design. For example:

- local government officers who have a role in planning shade for outdoor facilities and venues at parks, swimming pools and sporting fields
- employers who are responsible for health and safety in outdoor workplaces
- school principals and childcare centre directors who are responsible for the well-being of children using outdoor play and learning spaces
- operators and managers of outdoor facilities
- home owners who want to provide shade at their residences.

## Using this publication

This publication is structured to inform progressively the reader about the fundamental issues of shade planning and design. As each section contains vital information for effective shade planning, it is therefore suggested that Chapters 1–5 be read before Chapter 6, *Site specific considerations*. The text is cross-referenced where necessary.

It is also important that the relevant section of Chapter 6 be read before attempting to carry out the Shade Audit described in Chapter 5. The planning and design issues discussed in Chapter 6 will help shade planners adapt the Audit procedure to suit a particular site.

Every effort has been made to simplify what is sometimes a technical and complex issue. However, if some parts of the publication are found to be overly technical, it may be necessary to obtain professional advice, eg from architects, landscape architects or surveyors. Appendix B lists contact details for a number of relevant professional associations.

This publication aims to assist organisations and individuals to assess their specific circumstances and

develop appropriate solutions. The information is applicable to both the design of new facilities and the redevelopment of existing facilities.

## Responsibilities of public authorities\*

It is possible that public authorities may be found liable for not providing shade and warnings about skin cancer. In addition to owing a general duty of care at common law, there may well be particular statutory duties that are incumbent on councils or other public authorities which could found liability. Breach of either of these could result in liability being visited on public authorities.

However, in the face of growing evidence about the risks of melanoma and skin cancer from exposure to UVR, public authorities should be anxious to take appropriate steps to prevent further damage, especially to children, by pursuing policies now for the provision of shade in outdoor spaces under their management and control (see Appendix A).

---

\* Information supplied by KPMG Legal

# 2 Sun facts

## The sun and solar ultraviolet radiation

### The solar spectrum

Ultraviolet radiation (UVR) is part of the spectrum of electromagnetic radiation emitted by the sun. Other parts of the spectrum include gamma rays, X-rays, visible light, infra-red radiation and radio waves. Gamma rays, X-rays and very short wavelength UVR (called UVC) are absorbed by gases in the upper atmosphere and therefore do not affect us. Infra-red radiation can be felt as heat; visible light can be seen as light. Although present in sunlight, UVR can neither be seen nor felt.<sup>1</sup>

The different parts of the spectrum are referred to as energy bands and are characterised by varying wavelengths. UVR consists of the following different wavelength ranges:

- UVA with wavelengths between 315 and 400 nanometres (nm)
- UVB with wavelengths between 280 and 315 nm
- UVC with wavelengths between 100 and 280 nm.

#### the solar spectrum<sup>2</sup>

**UVA transmits freely through the earth's atmosphere.**

**Approximately 15% of the UVB entering the atmosphere reaches the earth's surface. This is due to absorption by stratospheric ozone.**

**UVB is the most biologically damaging form of UVR which reaches the earth's surface.**

**UVC is completely absorbed by stratospheric ozone and also atmospheric gases.**

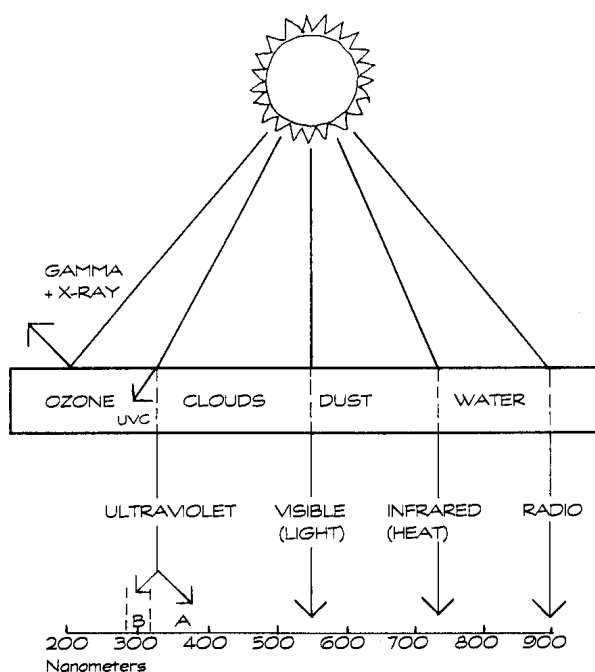

<sup>1</sup> Gies PH, Roy CR and Elliot G. Ultraviolet radiation protection factors for personal protection in both occupational and recreational situations. *Radiation protection in Australia* 1992;10:3.

<sup>2</sup> Groves G. *Sunburn, suntan and sunscreens*. Australian Cancer Society, 1981.

## The sun and solar ultraviolet radiation

### Direct and indirect UVR

UVR that reaches us directly from the sun is known as direct UVR.

UVR can be scattered by water droplets in clouds and other particles such as dust in the atmosphere. It can also be reflected by surfaces such as walls, pavements, sand and snow. When UVR is reflected or scattered, it is referred to as indirect UVR. While direct UVR travels in a straight line through the atmosphere, indirect UVR may come from any direction.

Indirect UVR can be more intense than direct UVR and can cause damage to the skin. For example, sunburn from reflected or scattered UVR can occur in shaded areas.

The ratio of direct to indirect UVR varies throughout the day. The combination of direct and indirect UVR will result in a greater risk of sunburn and skin damage than that of direct UVR alone.

#### minimal erythral dose (MED)

The amount of exposure to UVR required to produce the first detectable reddening of the skin is called the minimum erythral dose (MED). The time taken to receive the MED varies considerably between individuals, depending on their skin type.

Typically a fair-skinned person would receive the MED in 11 to 12 minutes at solar noon in summer in most parts of New

Zealand. At the equinoxes UVR levels are high enough to cause damage in 18 to 30 minutes. In the months May–July in New Zealand, except at high altitudes and in the snow, it would take so long to receive a MED that there is little or no risk of burning.

As sunburn is strongly related to an increased risk of melanoma, the MED is a useful measure of the intensity of biologically effective UVR.

#### direct and indirect UVR

There is more direct than indirect UVR at noon on a cloud-free day.

However, when the sun is low in the sky in the morning and evening, indirect UVR is more intense than direct UVR.

There are also some circumstances when indirect UVR can account for more than half of the total incidence of UVR. For example, partial cloud cover above snow fields creates high levels of indirect UVR, due to the combined effect of UVR being scattered by the clouds and reflected by the snow.

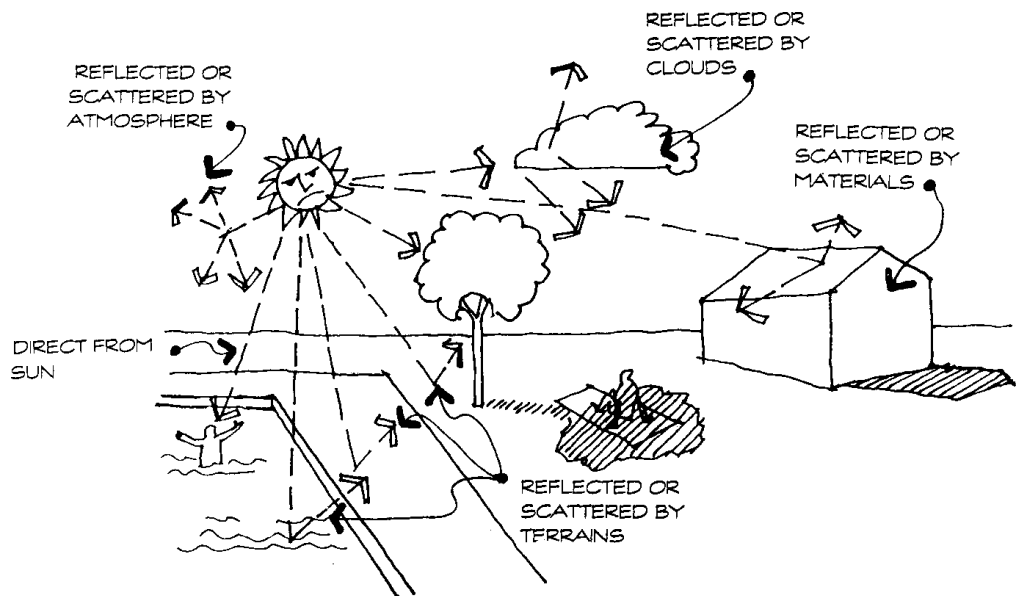

#### note

See Chapter 3, *Protecting against solar UVR*, for a discussion of the control of direct and indirect UVR.

#### note

Solar noon is the time of the day when the sun is at its highest point in the sky. In summer this occurs at about 1.30pm New Zealand daylight saving time.

## The sun and solar ultraviolet radiation

### Factors affecting UVR levels

#### season and time of day

The single most important factor affecting UVR levels is the height of the sun in the sky – the higher the sun, the higher the levels of solar UVR. During winter, UVB levels are considerably lower than those in summer. This is because the sun is lower in the sky in winter, and the path of the radiation through the atmosphere is longer. More UVR is absorbed and scattered.

The most intense UV is received when the sun is highest in the sky – UV radiation shows a strong daily variation, with peak values at noon. In summer this occurs at about 1:30 pm New Zealand daylight saving time.

The same process occurs on a daily basis. The solar UVR around noon is more intense than it is early and late in the day. More than 50 percent of the daily total of solar UVR is received within two hours either side of solar noon, when the sun is at its highest point in the sky.

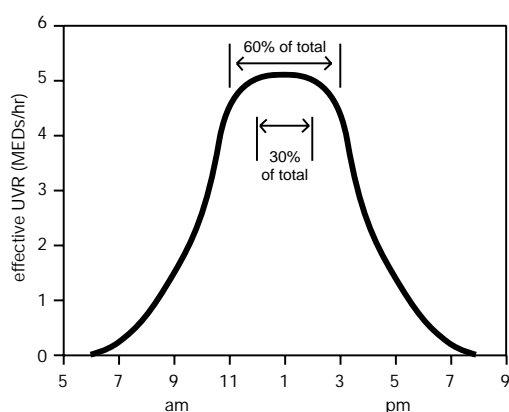

daily UVR variation in summer at a site at 34° latitude

#### geographic location<sup>4</sup>

The geographic location or latitude of a site determines, to an extent, the intensity of the radiation received.

New Zealand's UV is about 50 percent higher than at similar latitudes in Europe. The UV received here is much more intense than in the northern hemisphere at

comparable latitudes because of:

- the smaller sun–earth separation in during December and January
- hemispheric differences in ozone which result in less ozone in the southern hemisphere summer
- the generally more polluted skies in the northern hemisphere that provide further shielding.

UV radiation also tends to be highest in the north of New Zealand because the sun rises higher in the sky at those latitudes, and also because (contrary to public perceptions), there is generally less ozone there.

Site	Latitude (°S)	Summer Solstice 21 Dec	Autumn Equinox 21 Mar	Winter Solstice 21 Jun	Spring Equinox 21 Sep
Suva	18.2	14.6	12.6	6.8	12.2
Brisbane	27.4	13.8	10.3	3.9	9.4
Sydney	33.9	12.9	8.4	2.4	7.2
Kaitaia	35.2	12.7	8.1	2.2	6.9
Auckland	36.9	12.3	7.5	1.7	6.1
New Plymouth	39.1	11.8	6.8	1.4	6.4
Wellington	41.3	11.2	6.3	1.1	5.0
Christchurch	43.5	10.4	5.6	0.9	4.4
Dunedin	45.9	10.0	4.9	0.6	4.0
Invercargill	46.4	9.9	4.8	0.6	3.8
Campbell Island	52.6	8.2	3.3	0.2	2.7
Scott Base	77.9	2.9	0.3	0	0.6

Typical UV index values near midday for clear skies over New Zealand and its surrounding region. Seasonal variations are larger at high latitudes.

Refer to page 14 for burn times.

<sup>4</sup> McKenzie RL. Information supplied by National Institute of Water and Atmospheric Research. Further references available on request.

## The sun and solar ultraviolet radiation

### cloud cover

Cloud cover can significantly affect solar UVR levels, particularly UVB levels. Heavy cloud can reduce UVB to less than five percent of that present under clear skies. Scattered cloud has a variable effect, with the levels rising and falling significantly as clouds pass in front of the sun. In the absence of cloud, levels of UVB for consecutive days would be almost identical.

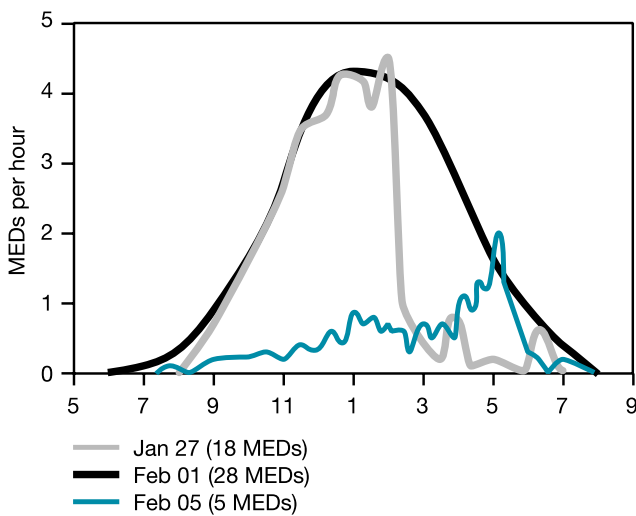

### effect of cloud on UVB <sup>5</sup>

This graph shows the effect of the different cloud conditions on the UVB levels (in MEDs) for three days in January and February 1996 in Melbourne. At 37°, Melbourne is at a similar latitude to Auckland. February 1 was virtually cloudless. The variation of UVB throughout the day shows the classic bell-shaped curve, with high levels of UVB at solar noon.

February 5 had heavy cloud resulting in the UVB levels remaining low all day.

January 27 was largely cloud-free until a front moved through in the early afternoon. UVB levels then dropped to almost zero.

On days with scattered cloud the effect on the UVB levels fluctuated from very low to high.

### stratospheric ozone

Ozone is a gas that is present in the earth's atmosphere. It is formed naturally in the upper atmosphere (the stratosphere). Ozone can also be found in the lower atmosphere as a component of industrial air pollution. In the stratosphere, ozone absorbs most of the UVR entering the atmosphere before it reaches the earth's surface.

New Zealand is not under the ozone hole but is affected when the ozone hole breaks up, and filaments of air with low levels of ozone move out from the Antarctic. As these filaments of air pass over New Zealand extreme variations in ozone levels can occur, especially during late spring. Over New Zealand ozone has declined by five to 10 percent in the last 15 to 20 years.<sup>6</sup> It has been estimated that for every one percent sustained decrease in ozone, there will be a 1.7 percent long-term increase in basal cell carcinoma and a 3.0 percent increase in squamous cell carcinoma of the skin. The increase of melanoma of the skin is less certain, but would probably be at least 0.4 percent for each one percent sustained decrease in ozone.<sup>7</sup>

### Conversions between UV Index and Burn Time<sup>4</sup>

Approximate conversions are given in the following table, although it is important to note the concept of burn time is not well defined.\*

UV Index	Burn Time (minutes)	Risk Description
0	-	No danger (dark)
1	144	Minimal
2	72	Minimal
3	48	Low
4	36	Low
5	29	Moderate
6	24	Moderate
7	21	High
8	18	High
9	16	High
10	14	Very High
11	13	Very High
12	12	Extreme
13	11	Extreme
14	10	Extreme

<sup>5</sup> Australian Radiation Laboratory – UVR Data Net October 1995;3.

<sup>6</sup> McKenzie et al. Increased summertime UV observed in New Zealand in response to ozone loss. *Science* 285, 1709–11, 1999.

### note

The predicted long-term decreases in stratospheric ozone are associated with the release into the atmosphere of industrial chemicals such as chlorofluorocarbons and halons which has occurred during recent decades.

\* Burn time is the approximate time it would take for fair, untanned skin to experience detectable reddening when exposed to the sun.

<sup>7</sup> Armstrong BK. The human health consequences of ozone depletion – An overview. *Australian Meteorological Magazine* 1997;46.

## The sun and solar ultraviolet radiation

### altitude and surrounding environment

Other factors which affect solar UVR levels are altitude and the surrounding environment.

UVR levels increase by approximately five percent with every 300 metres of altitude.<sup>4,8</sup> Hence, locations at higher altitudes such as the ski fields (approx 2000 m) can have significantly higher UVB levels than those at sea level.

Environments which contain highly reflective surfaces such as snow and sand have increased risk of high indirect UVR levels. At high altitude the presence of snow may be a more important factor than the altitude itself, since fresh snow is highly reflective.

#### UVR reflectance of ground surfaces<sup>9</sup>

surface	reflectance (%)
snow, old – new	50 – 88
sea surf, white foam	25 – 30
sand, wet – dry	7.1 – 18.0
concrete footpath	8.2 – 12.0
open ocean	8.0
boat deck, wood – fibreglass	6.6 – 9.1
asphalt roadway new (black) – old (grey)	4.1 – 8.9
soil	4.0 – 6.0
open water	3.3
lawn grass, summer – winter	2.0 – 5.0

### atmospheric dust and air pollution

Air pollutants and other particles in the atmosphere, such as dust, can also reduce UVB radiation at the earth's surface. However, these factors are usually less important than those described above.

### what is the UV Index?

The UV Index is a measure of how intense the UV is at any time. It is an international standard recommended by the World Health Organisation and the World Meteorological Organisation. The higher the index, the more intense the UV. An index of 10 or more should be considered to be 'very high'. The highest index for the New Zealand summer is usually about 12. For the technically minded, the UV Index is the intensity of sunburning radiation in Watts per square metre, but multiplied by 40 to give a more manageable number.

Many media outlets now publish or broadcast UV

Index readings in conjunction with weather forecasts from November to March.

Examples of the UV Index have been calculated for clear skies as functions of time of day and time of year for sites in New Zealand in the north and in the south. The figures show that the dominant factor is the sun's angle, causing variations of a factor of 10 between winter and summer so that the UV Index is rarely above one or two in the winter. Day to day variations of about 10 percent are due to daily fluctuations in ozone. Therefore, one would expect a similar pattern from year to year at each site.

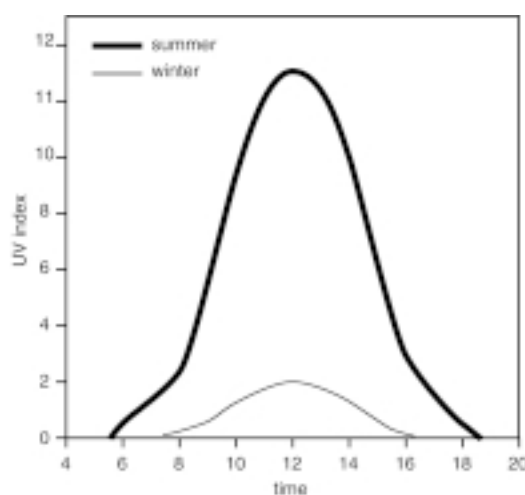

daily and seasonal variation in solar UV Index

<sup>8</sup> Diffey BL. Ultraviolet radiation in medicine. *Medical physics handbooks 11*. Bristol: Adam Hilger Ltd, 1992.

<sup>9</sup> Sliney DH. Physical factors in cataractogenesis: ambient ultraviolet radiation and temperature. *Investigative ophthalmology and visual science* 1986;27:5.

## The sun and solar ultraviolet radiation

### Health effects of exposure to solar UVR

UVR penetrates human tissue to a depth of 0.1–1 millimetre. The organs affected are the skin and the eyes.

UVR exposure contributes to a number of effects on the skin including:

- sunburn (erythema)
- skin ageing (solar elastosis)
- skin cancer.

There are three main types of skin cancer: melanoma, squamous cell carcinoma and basal cell carcinoma. All are caused by sun exposure.

Although the least common of the UVR-related skin cancers, melanoma is the most dangerous. In 1996, it was the cause of nearly 200 deaths in New Zealand.<sup>10</sup> Melanoma of the skin usually starts in the pigment cells (melanocytes) of the epidermis. The epidermis is the outer layer of the skin and consists of four or five cell layers. A melanoma tends to spread out within the epidermis before moving into the deeper layers of the skin.

While a melanoma is still only in the epidermis, it can be completely cured by surgery. Once a melanoma has spread into the dermis (the inner layer of the skin which lies beneath the epidermis) it is known as an invasive melanoma. From here, cancer cells may break away and spread through blood and lymph vessels to other parts of the body.

Basal cell carcinoma (BCC) and squamous cell carcinoma (SCC) are referred to as non-melanocytic skin cancers (NMSC) and occur in the basal and squamous cells respectively. Basal cells form at the base of the epidermis and gradually move upwards towards the surface of the skin to replace dying cells. During their upward journey they become flattened and are then referred to as squamous cells. BCCs account for 70 to 80 percent of skin cancers while SCCs account for 15 to 20 percent.

While BCCs rarely kill, the risk of death from SCCs is greater. In 1996, there were 60 deaths in New Zealand from NMSCs,<sup>10</sup> most likely a result of SCCs. Despite the low risk of death from BCCs they, if left untreated, can spread to surrounding skin and erode underlying tissue causing extensive damage and disfigurement.

Eye damage can also occur as a result of acute or prolonged UVR exposure. This damage includes:

- painful eye inflammation, eg snow blindness
- a growth over the cornea (pterygium)
- cloudiness of the lens (cataract)
- cancer on the surface of the eye.

A number of these conditions can lead to blindness.<sup>11</sup>

<sup>10</sup> New Zealand Health Information Service. *Mortality and demographic data 1997*. Wellington: Ministry of Health, 2000.

<sup>11</sup> Roy CR, Gies HP and Elliott G. Solar ultraviolet radiation: Personal exposure and protection. *Journal of Occupational Health and Safety* 1988;4:2.

## Earth–sun relationships

### Sun angles and their effects on shadow

The main objective of shade planning is to provide shade at the right place, at the right time of the day, at the right time of the year. Unfortunately, the location of shade structures and trees often produces a shadow pattern entirely different from that anticipated.<sup>12</sup>

Accurately predicting where a tree or structure will cast its shadow depends on an understanding of the sun's path. Such an understanding is fundamental to effective shade planning.

It is essential to know three things about a site in order to accurately assess the effect of the sun's path.

These are:

- latitude
- longitude
- the direction of true north.

If these are known, it is possible to use sun charts or commercially available computer programmes to find the position of the sun for any time of day throughout the year.<sup>13</sup>

To accurately predict the behaviour of shadows cast by solid objects it is essential to know the solar azimuth angle and the solar altitude angle.

#### solar azimuth angle: direction of shadow

The azimuth determines the direction in which the shadow will fall on the ground.

Solar azimuth is the angle, in a horizontal plane, between true north and the direction of the sun, measured clockwise from true north. It can have any value from 0° to 360°. The azimuth at solar noon in the southern hemisphere is always 0°.

#### solar altitude angle: length of shadow

The solar altitude angle determines the length of the shadow cast by a solid object on the ground.

Solar altitude is the angle between the sun and the horizon at a given latitude. It varies according to the time of the day and according to season.

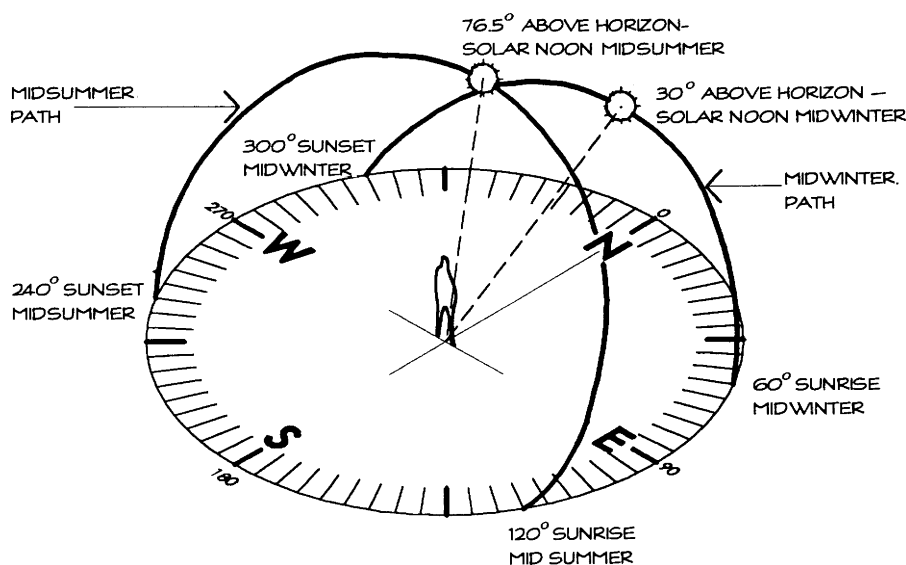

solar azimuth and altitude angles in Auckland

<sup>12</sup> Oakman H. *Tropical and subtropical gardening*. Milton: The Jacaranda Press, 1981.

<sup>13</sup> Ballinger JA, Prasad DK, Rudder D. *Energy efficient Australian housing*. Canberra: Australian Government Printing Service, 1992.

#### note

While containing basic information on the earth–sun relationships, this chapter is particularly relevant for those undertaking the 'projection' method of the Shade Audit. See the Shade Audit section in Chapter 5.

## Earth–sun relationships

### Daily path

As the sun is continuously moving across the sky, the shadows cast by the sun are always moving. They slowly shift from sunrise to sunset in response to the altitude and azimuth of the sun as it passes from east to west.

This basic pattern applies every day of the year, although the areas affected by shadow vary according to the time of the year. The sun's path changes throughout the year but always follows the same sequence year after year.<sup>14</sup>

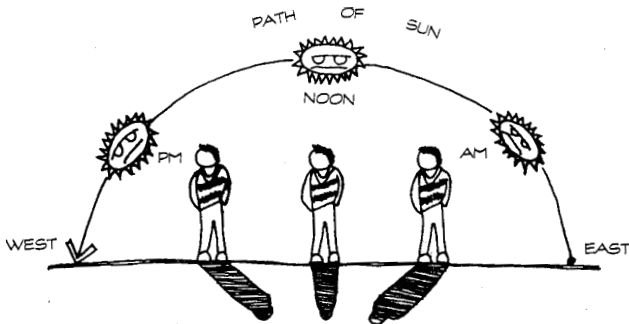

#### sun's daily path

There are three basic shade patterns every day:

**morning** – when the shadow will fall in a westerly direction away from the object casting the shadow

**midday** – when the shadow will be close beneath the object  
**afternoon** – when the shadow will fall in an easterly direction away from the object.

### Annual path

Because the earth's axis is tilted to the plane of its solar orbit, the north–south angle of the sun (measured by the azimuth) moves according to the season. This is the main cause of seasonal changes.

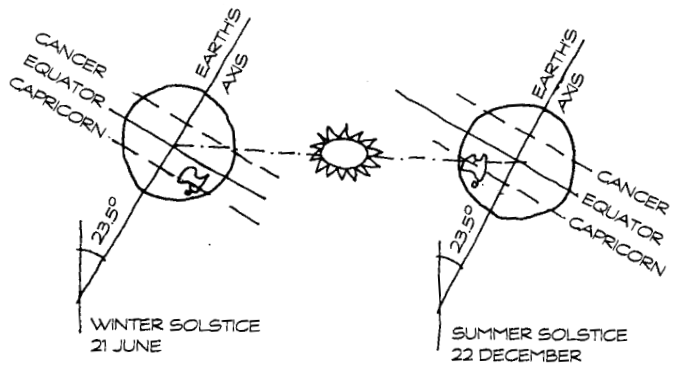

#### earth–sun relationship at winter and summer solstice

In the southern hemisphere, the sun is furthest south in summer and more directly overhead. In winter it is towards the north, and thus lower in the sky. This

earth–sun relationship means that the area of the earth's surface receiving the maximum solar intensity moves between the Tropic of Capricorn (latitude 23.5°S) and the Tropic of Cancer (latitude 23.5°N).

<sup>14</sup> Koenigsberger OH and Ingersol TG. *Manual of tropical housing and building – Part 1 Climatic design*. New York: Longman Inc, 1974.

## Earth–sun relationships

The earth–sun relationship affects the amount of solar radiation (including UVR) received at a particular point on the earth's surface in the following three ways.

### 1 solar altitude angle and UVR intensity

The lower the solar altitude angle, the lower the intensity of radiation falling on an area.

Lower angle = greater area  
greater area = less intensity of radiation.

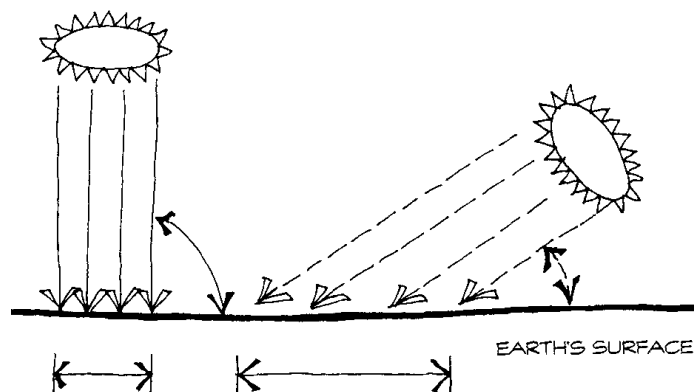

### 2 distance and UVR intensity

The lower the solar altitude angle, the longer the path of radiation through the atmosphere. Less radiation, including UVR, reaches the earth's surface as more radiation is absorbed by ozone, vapours and dust particles in the atmosphere.

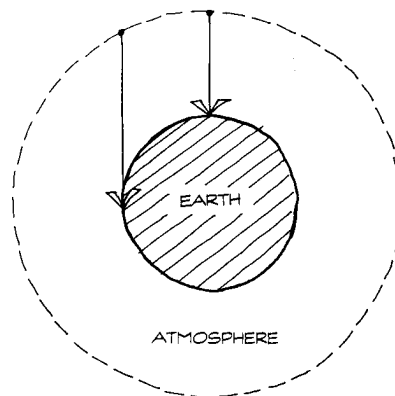

### 3 solar altitude angle and daylight

The lower the solar altitude angle, the shorter the daylight period.

## Earth–sun relationships

### Equinox and solstice

Four particular days of the year are important for marking the sequence of the sun's path:

- the equinox days – 21 March and 23 September, when day and night are of equal length, each being 12 hours
- the winter and summer solstice – 21 June and 22 December. The winter solstice is when the shortest day (that is, the shortest daylight period) occurs. Conversely the summer solstice is the longest day of the year.

In the southern hemisphere, from 21 March until 23 September, the sun rises to the north of east. Similarly it sets to the north of west. From 23 September until 21 March the sun rises to the south of east and sets to the south of west.

The equinox and solstice are particularly relevant to the shade planner as they are the dates at which the shadows cast by shade-creating barriers or objects, eg a tree, wall or building, should be typically plotted. This will help to ensure that the shade project results in shade at the right place, at the right time of day, at the right time of year. Fortunately, the solar altitude angles at equinox and solstice can be easily calculated.

The solar altitude angle at solar noon on the equinox days for any given location is equal to the complementary angle of the latitude of the location (that is,  $90^\circ$  minus latitude).<sup>15</sup>

On the *winter* solstice, the solar altitude angle at solar noon is equal to the altitude angle at the equinox *minus*  $23.5^\circ$ .

On the *summer* solstice, the solar altitude angle at solar noon is equal to the altitude angle at the equinox *plus*  $23.5^\circ$ .

#### solar altitude angles for Auckland and Christchurch on the equinox and solstice days at solar noon

		solar altitude angles at solar noon		
	latitude	equinox	winter solstice	summer solstice
Auckland	$37^\circ$	$90^\circ - 37^\circ = 53^\circ$	$53^\circ - 23.5^\circ = 29.5^\circ$	$53^\circ + 23.5^\circ = 76.5^\circ$
Christchurch	$43.5^\circ$	$90^\circ - 43.5^\circ = 46.5^\circ$	$46.5^\circ - 23.5^\circ = 23^\circ$	$46.5^\circ + 23.5^\circ = 70^\circ$

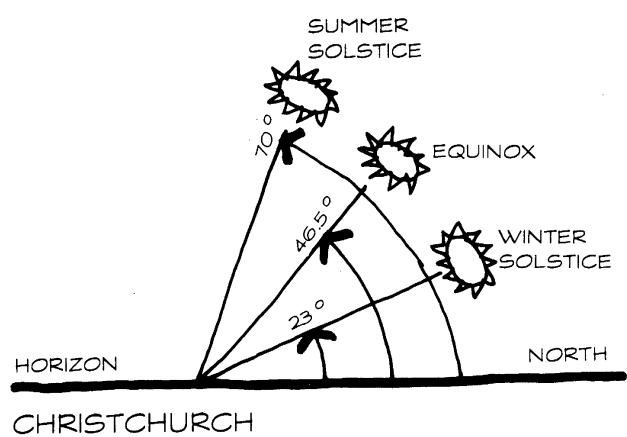
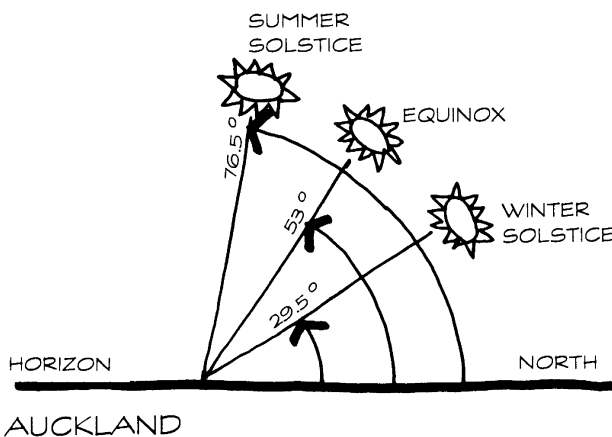

### note

The use of solar altitude angles for plotting shade is particularly relevant to the 'projection' method of the Shade Audit. See the Shade Audit section in Chapter 5.

<sup>15</sup> Phillips RO. *Sunshine and shade in Australia*. Commonwealth Scientific and Industrial Research for Australia, 1992.

## Shadow angles

The shade designer must be able to anticipate the shadow that will be cast on the ground by a shade-producing barrier such as a structure or tree. As discussed, calculation of the solar altitude and azimuth angles will allow this to be determined. This will be sufficient for many outdoor situations. For example, the shade pattern cast by trees or a freestanding shade structure in a park can be understood by using solar azimuth and altitude angles only.

In some situations a more detailed knowledge of the shade that will be cast by a structure is required. For example, when designing a building for a temperate climate in New Zealand, it may be desirable to exclude the sun in summer but admit it in winter. In situations such as this, it is necessary to determine accurately sun and shade patterns relative to the windows or other openings by using horizontal and vertical shadow angles. However, a general understanding of the concepts involved may be useful for the lay shade planner.

The shade-producing performance of physical barriers to the sun's direct rays is specified by two angles:

- the horizontal shadow angle
- the vertical shadow angle.

Together, these angles will allow the shade designer to accurately predict the area on which shade will fall on any day of the year; and the pattern of that shade at any time of the day.

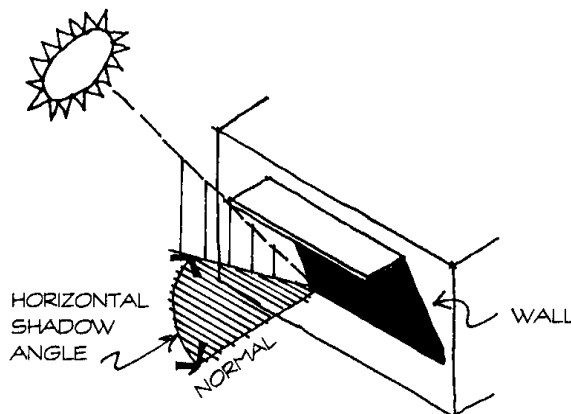

### horizontal shadow angle

A vertical shading device such as a wall, fence, screen or line of trees is characterised by a horizontal shadow angle.

The horizontal shadow angle is the difference between the solar azimuth angle and the angle at which the wall is oriented.

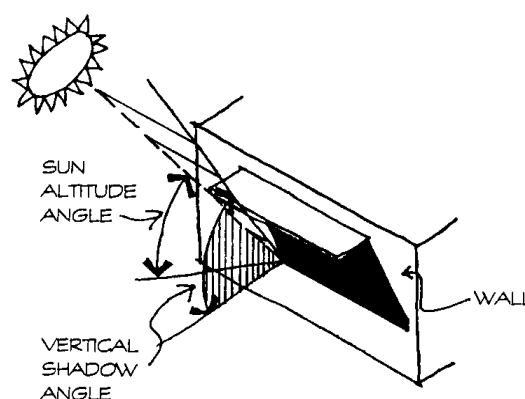

### vertical shadow angle

A horizontal shading device such as a canopy, awning or other projection is characterised by a vertical shadow angle.

This is measured on a vertical plane perpendicular to the edge of the area to be shaded. The shade designer can determine the vertical shadow angle using a shadow angle protractor or by calculation.

## note

Assessing the complex design issues presented by horizontal and vertical shadow angles is a specialised task and should be undertaken by shade design professionals such as architects. See Appendix B for a list of relevant professional associations.



# 3 Protecting against solar UVR

## Environmental strategies for controlling solar UVR

---

Maximum protection from solar UVR can be achieved through a combination of personal and environmental strategies.

The most effective personal protection strategy is to minimise sun exposure between 11am to 4pm daylight saving time during summer. When people are outdoors it is important that they protect themselves from the sun by wearing protective clothing, sunhats, sunscreen and sunglasses, as well as using available shade.

Environmental strategies seek to support personal protection strategies by creating outdoor spaces that provide protection from both direct and indirect UVR. Examples of environmental strategies include:

- placing UVR protective barriers above, and to the side of, the designated area
- reducing reflection of UVR from nearby surfaces into the designated area
- increasing the size of the shaded area to allow people to use the centre of the area rather than its edges.

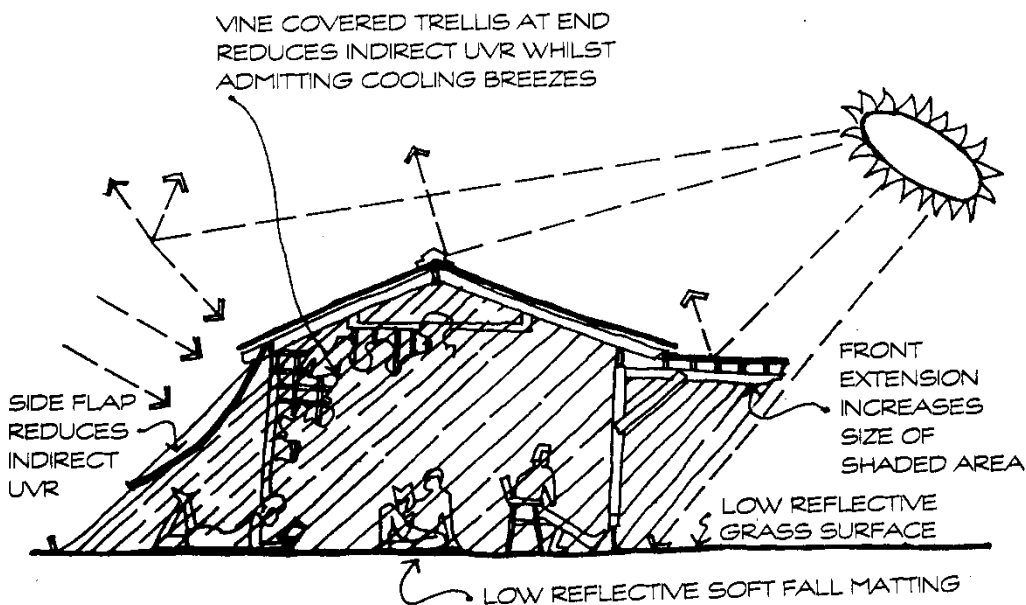

environmental strategies for protecting against solar UVR

---

Environmental strategies

Control of direct UVR

The most common method of controlling direct UVR is to place a barrier so that it intercepts the sun's rays, thus creating shade. Such barriers can include both built items and natural barriers such as trees and other vegetation. For the barrier to provide effective protection during the required period, it should:

- be of sufficient size
- be located in the right place.

Effective barriers to UVR must allow for daily and seasonal sun movement. Too often, shade canopies are erected or trees are planted on the assumption that they will provide the required shade, when the actual shadow pattern is quite different.<sup>1</sup>

A decision on whether to use built or natural barriers to UVR will be strongly influenced by the specific shade needs and other site considerations. As built shade lends itself to greater design possibilities, this approach is often the most adaptable to the particular needs of a site.

However, the use of natural shade also has advantages. These include the cooling effect of trees and the enhancement of the aesthetic qualities of a site. In many situations a combination of built and natural components will be most appropriate.

quality of shade created by UVR protective barriers

The quality of shade created by a barrier is determined by the characteristics of its constituent materials and, in the case of built shade, its design.

Good quality shade:

- provides at least 94 percent protection (at least UPF 15) from direct UVR
- creates an environment that is comfortable to use in both summer and winter.

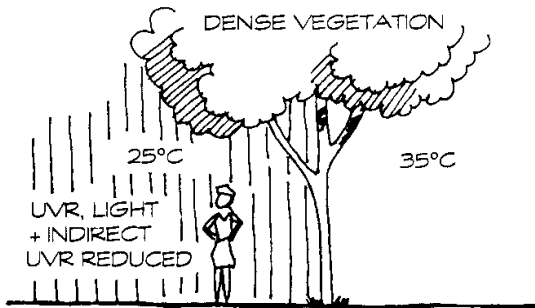

summer protective shade

The high UVR levels experienced throughout New Zealand in summer mean that the provision of shade during these months should be a priority. Summer shade provision should minimise UVR levels, as well as reduce heat and light.

The aim is to create an environment which is shaded and cool. This may be achieved by tree planting, or by the use of materials that significantly exclude heat and light, as well as UVR.

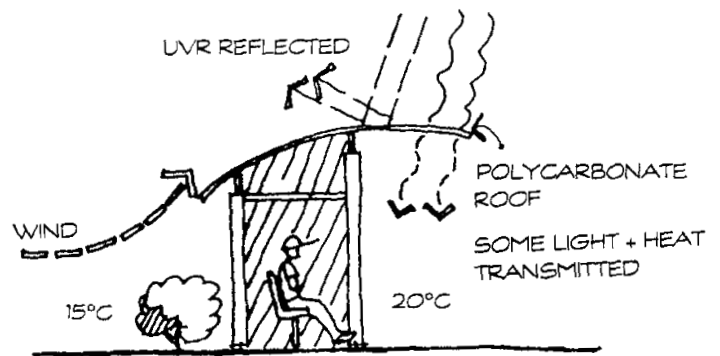

winter protective shade

UVR levels are low between May and July, so the main consideration is allowing for transmission of sufficient heat and light. As shade structures are likely to be used year

round, the aim is to create an environment that provides winter warmth, as well as coolness and protection from UVR in the summer.

<sup>1</sup> Oakman H. *Tropical and subtropical gardening*. Milton: The Jacaranda Press, 1981.

## Control of indirect UVR

The control of indirect UVR is an important consideration in any shade project.

Indirect UVR is reflected off surface materials or scattered by clouds or atmospheric particles. Therefore it can come from any direction. Because of this, it is difficult to provide shade which completely excludes UVR. Nevertheless, control of indirect UVR will be more effective if the behaviour and sources of both reflected and scattered UVR are understood.

### reflected UVR

In most instances, reflected UVR will comprise only a small component of the total UVR present at a particular site. The notable exceptions to this general rule-of-thumb are locations characterised by the presence of snow or sand. Snow can reflect in excess of 80 percent of the UVR it receives, and sand up to 18 percent. However, the reflectance of most natural and artificial surfaces is usually less than 10 percent. Refer to the table on page 15 for the reflectivity of different ground surfaces.

The reflectance of a surface varies as the solar altitude angle, ie the height of the sun, changes. Most ground surfaces do not uniformly reflect UVR in all directions, but depend on the direction of incoming radiation. Accordingly, it is generally the case that higher levels of reflected UVR are experienced early and late in the day, while the highest levels of direct UVR are experienced at solar noon.

Reflectance of UVR should not be confused with the reflectance of light. While the amount of visible light reflected from a surface is influenced by colour, the reflectance of UVR is independent of colour. Therefore, a material that is good at reflecting visible light may not reflect much UVR. For example, the UVR reflectance of paint is low and is independent of colour.<sup>2</sup> Generally, the selection of surface materials to minimise reflected UVR should take into account:

- surface density – hard surfaces such as paving will reflect higher levels of UVR than softer surfaces such as grass or soil
- surface finish – smooth surfaces such as metal sheeting and smooth trowelled concrete reflect higher levels of UVR than coarse or varied surfaces such as timber cladding, roof tiles or brick paving.

### scattered UVR

Protection from scattered UVR is achieved by reducing exposure to the sky. Generally, a site receives as much scattered UVR from the sky, as direct UVR.<sup>3</sup> If a person sitting in shade is able to see a lot of blue sky, scattered UVR is able to reach them.

In many situations, the contribution of scattered UVR to the total UVR reaching a site will exceed that of the reflected UVR reaching the site. For example, this would occur when boating on open water because reflectance from open water is low.

## note

Built shade, natural shade and combined shade systems are discussed in detail in Chapter 4, *Providing shade*.

<sup>2</sup> Sliney DH and Wolbarsht ML. *Safety with lasers and other optical sources*. New York: Plenum Press, 1980.

<sup>3</sup> Gies PH, Roy CR, Toomey S and McLennan A. Protection against solar UV radiation. Sun Protection Seminar Papers. Australian Cancer Society, 1997.

**Environmental strategies**

**Design strategies for the control of indirect UVR**

There are a number of design strategies that can be used to reduce an area's exposure to indirect UVR (as well as direct UVR).

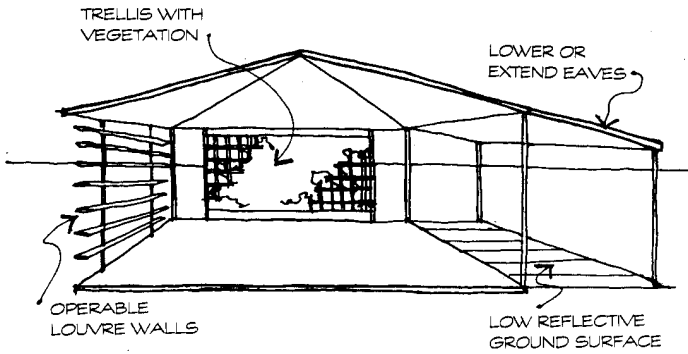

**extend overhead barriers past actual use areas**

A simple rule-of-thumb is to make sure there is at least a one metre overhang past the actual area of use. Laterally extending devices such as roller blind awnings can be useful for extending overhangs on existing structures.

**take account of external sources of reflected UVR from existing buildings and adjoining properties**

For example, if the property next door has a large, reflective wall facing your site, design a shade system that blocks the reflected UVR. Possible solutions may be to provide vertical screening using opaque louvres or a trellis. Avoid shade systems that reflect UVR onto other areas or adjoining properties.

**combining strategies to control indirect UVR**

**ensure shade structures are of an adequate size**

The larger the shaded area, the greater the opportunity to avoid indirect and direct UVR. This is because UVR levels will be greater towards the edges of the shaded area.

**use barriers for side as well as overhead protection**

Vertical screening with plants and trellises or a system of opaque louvres can provide a barrier to indirect UVR, while admitting ventilation and breezes.

**choose materials that reduce reflectivity**

Soft surfaces and those with uneven finishes will reflect lower levels of UVR than other surfaces. For example, vegetation absorbs and scatters UVR, which decreases its intensity. Plant ground covers or grass in preference to the use of concrete paving.

Existing reflective surfaces can be altered to reduce indirect UVR. In a playground, concrete or bitumen surfaces can be treated to reduce reflectivity. Block the amount of direct UVR hitting the ground surface by overhead shading. Use coloured rubber matting (soft fall matting) or synthetic turf to reduce reflected UVR.

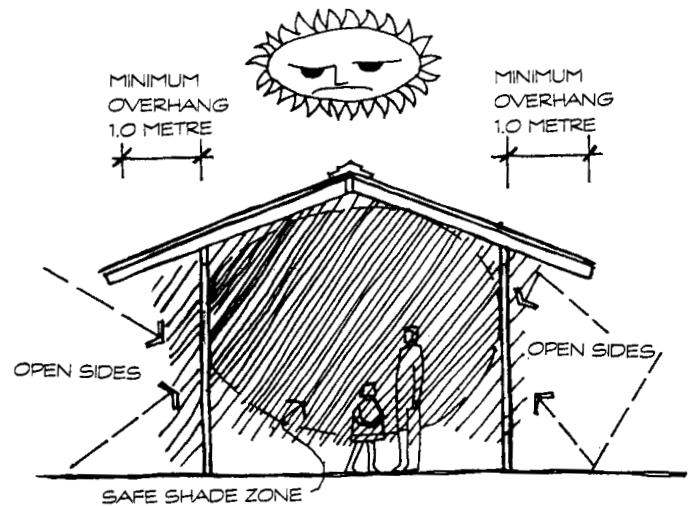

**using an extended overhang to reduce indirect UVR**

## Designing shade for climate and comfort

# Designing shade for climate and comfort

## Shade planning for specific climate zones

It is important to become familiar with the climatic elements of a location in order to design UVR protective shade that is comfortable for human use at the right time of the day and at the right time of the year. If a shelter does not address human comfort, it will not be an effective control against over exposure to UVR, because it will not be attractive for use.

The four elements of a climate which have a dominant influence on human comfort are:

- air temperature
- humidity, or water content of the air
- air movement (breeze)
- heat radiated from the sun and from the surroundings.

Each influences in some way the heat exchange processes between the human body and its environment. All must be considered together if the effects on people are to be predicted.

For example, when the weather is cold the effect of humidity is barely noticeable, but when it is hot, high humidity becomes less tolerable. Air movement at our body surface causes evaporation of perspiration and has a cooling effect. At higher humidities such evaporation is prevented or at least reduced. Wind does not change the air temperature but it makes us feel cooler. To some extent it can compensate for the effect of high humidity.

When climatic elements are understood, it is possible to design outdoor environments that provide increased levels of comfort by modifying the existing conditions. For example:

- if it is hot and humid, provide shading to exclude the sun and allow cross-ventilation to capture the breeze for cooling
- if it is cold and windy, provide wind breaks to exclude the breeze, and select UV protective materials that exclude UVR whilst transmitting light and heat (eg polycarbonate, glass).

Shade offers the physical sensation of a change of temperature. Sheltered from the direct heat of the sun's rays, shady areas are perceived as cooler. Direct sunshine usually feels hotter, so shade is sought out on a summer's day to escape the heat as much as to escape exposure to UVR.

On cooler days in the months around the equinoxes, people prefer to be warmed by the sun and will tend to avoid shady spots, even though risk of UVR exposure is still present. For these times of year, it is necessary to create warm outdoor environments which also offer protection against UVR.

During the cooler months (May through August) when UVR levels are low, the main consideration is to provide outdoor spaces that are warm, light and protected from winds.

### note

Effective shade systems address human comfort factors as well as control of UVR.

## Climate zones of New Zealand<sup>4</sup>

New Zealand has a wide range of regional and local (micro) climates. The lie of the mountainous regions of both islands (especially the Southern Alps), combined with a prevailing westerly airflow has a major effect on our climate. High rainfall is common in and west of the South Island mountain ranges, while much drier (almost semi-arid) conditions often prevail in the east of the South Island.

Sunshine hours are relatively high in areas sheltered from the west, such as Marlborough, Nelson, Bay of Plenty, Gisborne, Hawke's Bay, and inland areas of both south Canterbury and Otago. Areas exposed to prevailing air-streams, such as Fiordland, and the Southland and Otago coasts, tend to be cloudier.

New Zealand's climate is complex but, for the purposes of this publication, ten broad climate zones have been identified.

The boundaries between these zones can, at best, be described as rough lines, as one climate regime merges into another. Influences such as valleys, nearby hills, aspect, urbanisation, the presence of lakes and coastal weather patterns all affect local climates.

### Climate characteristics

Major characteristics for each climate zone are presented in the following sections. Special conditions, which should be taken into account during the design of shade, are noted. Strategies to deal with these conditions are recommended.

### New Zealand climate zones

Climate zone	Regions/areas included
1) Northern New Zealand	Northland, Auckland, Coromandel, Bay of Plenty
2) Eastern North Island	Gisborne, Hawke's Bay, Wairarapa
3) Central North Island	Waikato, King Country, Taupo/Rotorua
4) Southwest North Island	Taranaki, Wanganui, Manawatu, Wellington
5) Northern South Island	Marborough, Nelson, Golden Bay
6) Western South Island	Buller, Westland, Fiordland
7) Eastern South Island	Kaikoura Coast, northern and coastal Canterbury
8) Inland South Island	Inland Canterbury, Central Otago
9) Southern New Zealand	Southland, coastal Otago, Stewart Island
10) Mountainous/alpine areas	



<sup>4</sup> Burgess, S.M. National Institute of Water and Atmospheric Research Ltd. Information supplied to the Cancer Society. References available on request.

## Designing shade for climate and comfort

### 1. Northern New Zealand

Northern New Zealand includes the Northland, Auckland, Coromandel and Bay of Plenty regions.



This is a sub-tropical climate zone that is less vulnerable to outbreaks of cold air than the rest of the country. However, storms of tropical origin can occur in summer and early autumn, with high winds and heavy rainfall from the east or northeast. Localised lightning and thunderstorms can occur.

- warm and humid in summer. Typical summer temperatures 22° C to 26° C but seldom exceed 30°C
- winters are mild but can be unsettled with higher rainfall. Typical winter temperatures 12° C to 17°C\*
- annual sunshine hours average 2000 in many areas. The summer UVI is often extreme. Autumn and spring UVI values can also be high
- southwesterlies prevail for much of the year. Sea breezes often occur on warm summer days.

#### design considerations

- shade should be accessible from September through April
- access to winter sun is recommended
- cooling is recommended in the hottest part of the year
- allow access to cooling sea breezes in summer
- protection against cool southwesterly winds required in winter
- structures should be designed to withstand strong winds
- use of natural shade is recommended as vegetation in this climate zone grows well.

### 2. Eastern North Island

Eastern North Island includes the Gisborne, Hawke's Bay and Wairarapa regions.



The North Island high country to the west shelters most of this zone, which has a dry sunny climate. Temperatures in summer are often high and may be accompanied by strong dry (foehn) winds from the northwest. Passing cold fronts can cause large temperature changes, especially if the fronts are followed by cold southerlies. Rainfall can be heavy from the east. Warm, dry and settled weather predominates during summer. Frosts may occur in winter.

- typical summer air temperatures 20° C to 28° C, occasionally above 30° C. Extreme temperatures (39° C) have been recorded
- winter is milder in the north, and cooler in the south. Typical winter temperatures range from 10° C to 16° C
- annual sunshine hours average 2200 in Gisborne and central Hawke's Bay, through to 1800 to 2000 hours in southern Hawke's Bay and Wairarapa. The midday summer UVI is often very high. Autumn and spring UVI values can be high
- westerly winds prevail. Sea breezes often occur in coastal areas on warm summer days.

#### design considerations

- shade should be accessible from September through April
- access to winter sun is recommended, especially in the southern areas
- cooling is required in the hottest part of the year
- allow access to cooling sea breezes in summer
- protection against cool southerly and westerly winds required in winter
- use of natural shade is recommended as vegetation in this climate zone grows well.

\* Temperatures refer to typical daytime temperatures throughout.

### 3. Central North Island

Central North island includes the Waikato, King Country, Tongariro and Rotorua regions. Note that the volcanic mountainous areas are covered in Section 10.



Most of this climate zone experiences less wind than many other parts of New Zealand because the area is sheltered by the North Island high country to the south and east. The inland location means temperatures vary widely. Warm dry and settled weather predominates during summer. Frost occurs in clear, calm conditions in winter.

- typical summer daytime maximum air temperatures range from 21° C to 26° C but rarely exceed 30° C
- winters are cool, especially towards the North Island central plateau. This is normally the most unsettled time of the year. Typical winter daytime maximum air temperatures range from 10° C to 14° C
- annual hours of bright sunshine average 2000 to 2100 hours in many areas. However, the western hill country is much cloudier, with less than 1800 hours. The midday summer solar ultra violet index (UVI) is often very high. Autumn and spring UVI values can be high
- southwesterlies prevail. Lake breezes often occur in Taupo and Rotorua on warm summer days .

#### design considerations

- shade should be accessible from September through April
- access to winter sun is a necessity
- cooling is recommended in the hottest part of the year
- allow access to cooling lake breezes in Taupo and Rotorua in summer
- use of natural shade is recommended as vegetation in most of this climate zone grows well.

### 4. Southwest North Island

Southwest North Island includes Taranaki, Wanganui, Manawatu, and Wellington.



This zone is exposed to disturbed weather systems from the Tasman Sea and is often quite windy but with few climatic extremes.

Northwesterly airflows prevail and sea breezes may occur along the coast during summer. Summer and early autumn are the most settled seasons and frost occurs inland during clear, calm conditions in winter.

- summers are warm. Typical summer daytime maximum air temperatures range from 19° C to 24° C but seldom exceed 30° C
- winters are relatively mild in the north, but are cooler in the south. This is normally the most unsettled time of the year. Typical winter daytime maximum air temperatures range from 10° C to 14° C
- annual hours of bright sunshine average about 2000 in many areas. However, inland Manawatu and Horowhenua are much cloudier, some areas having less than 1800 hours of sunshine. The midday summer solar ultra violet index (UVI) is often very high. Early autumn and late spring UVI values can be high.

#### design considerations

- shade should be accessible from September through April
- access to winter sun is a necessity, particularly in southern areas
- cooling is recommended in the hottest part of the year
- consider allowing access to cooling sea breezes in summer
- protection against cool northwesterly and cold southerly winds required in winter
- structures should be designed to withstand strong winds
- use of natural shade is recommended as vegetation in many parts of this climate zone grows well.

## Designing shade for climate and comfort

### 5. Northern South Island

Northern South Island includes the Marlborough, Nelson and Golden Bay regions. Note that mountainous regions are covered in Section 10.



Shelter provided by high country to the west, south and east means this climate zone is the sunniest region of New Zealand. Nelson has less wind than many other urban centres. Warm dry and settled weather predominates during summer. Winter days often start with frost, but are usually mild overall.

- Nelson temperatures are often moderated by sea breezes. High temperatures are frequent in Marlborough, sometimes with strong dry foehn winds from the northwest. Typical summer temperatures 20° C to 26° C, but occasionally rise above 30° C in Marlborough, where extreme temperatures (42° C) have been recorded
- late winter and early spring is normally the most unsettled time of the year. Typical winter temperatures 10° C to 15° C
- annual sunshine hours average at least 2300 hours. The summer UVI is often very high. Early autumn and late spring UVI values can be high
- northeast winds prevail in Nelson, while southwesterlies prevail about Marlborough.

#### design considerations

- shade should be accessible from September through April
- access to winter sun is recommended
- cooling is recommended in the hottest part of the year, particularly in Marlborough
- allow access to cooling sea breezes in summer in the Nelson area
- use of natural shade is recommended as vegetation in this climate zone grows well.

### 6. Western South Island

Western South Island includes the Buller, Westland, and Fiordland regions.



Weather systems from the Tasman Sea and the lie of the massive Southern Alps to the east have a major impact on this climate zone.

Although mean annual rainfall is very high, dry spells do occur, especially in late summer, and during winter. Heavy rainfall occurs from the northwest.

- summers are mild with temperatures moderated by the sea. Typical summer temperatures 17°C to 22°C. Maximum temperatures seldom exceed 25°C
- winter days often start with frost, but are usually milder in the north. Typical winter temperatures 10°C to 14°C
- annual sunshine hours average 1800 to 1900 hours. The summer UVI is often very high. Early autumn and late spring UVI values can be high
- north-northeast winds prevail along the coast in the northern half of the region, while coastal southwesterlies prevail in the south. Sea breezes can occur on warm summer days.

#### design considerations

- shade should be accessible from September through March
- access to winter sun is a necessity
- protection against cool winds required in winter
- structures should be designed to withstand strong winds
- use of natural shade is recommended as vegetation in this climate zone grows well.

## 7. Eastern South Island

Eastern South Island includes the Kaikoura coast and Canterbury (except inland areas). Note that mountainous areas are covered in Section 10.



The lie of massive Southern Alps to the west has a major effect on this climate zone.

Summers are warm, with the highest temperatures occurring when hot dry foehn north westerlies blow over the alps and plains. Abrupt temperature changes can occur when cold fronts pass over the region, followed by cold southerlies or southwesterlies. Winters are cold with frequent frost. Mean annual rainfall is low, and long dry spells can occur, especially in summer. Summer temperatures are often moderated by a cool northeasterly sea breeze. Winters are cold, with frequent frosty conditions.

- typical summer temperatures 18° C to 26° C, but may rise to more than 30° C (often with dry gusty northwesterly conditions). Temperatures seldom exceed 34° C. The highest temperature recorded is 42° C
- typical winter temperatures range from 7° C to 14° C
- annual sunshine hours average 2000 hours in the north, and 1800 to 1900 hours in the south. The summer UVI is often very high. Early autumn and late spring UVI values can be high
- northeasterlies prevail about the coast. Southwesterlies are more frequent during winter.

### design considerations

- shade should be accessible from September to March
- access to winter sun is a necessity
- cooling is recommended in the hottest part of the year
- allow access to northeasterly sea breezes in summer
- the need for passive winter heating is an important consideration
- protection against cool south and southwesterly winds required in winter
- structures should be designed to withstand strong winds
- use of natural shade is recommended in areas where vegetation grows well.

## 8. Inland South Island

Inland South Island includes inland areas of Canterbury, such as the McKenzie Basin, along with Southern Lakes and Central Otago. Note that mountainous zones are covered in Section 10.



This climate zone is greatly dependent on the lie of massive Southern Alps to the west but many areas are also sheltered by high country to the south and east. Summer afternoons are very warm, with the highest temperatures occurring when hot dry foehn northwesterlies blow over the alps. Abrupt temperature changes can occur when the northwesterlies are followed by cold southerlies or southwesterlies. Winters are very cold with severe frosts and occasional snowfall which can lie for several days. Mean annual rainfall is low, and long dry spells can occur, especially in summer.

- typical summer temperatures 18° C to 26° C, occasionally rising above 30° C
- typical winter temperatures 3° C to 11° C
- annual sunshine hours average 1900 hours over most of the region but the McKenzie Basin has at least 2200 hours. The summer UVI is often very high. Early autumn and late spring UVI values can also be high
- wind flow is very dependent on the local topography. The strongest winds are often from the northwest.

### design considerations

- shade should be accessible from September to March
- access to winter sun is a necessity
- protection against cool winds required in winter
- the need for passive winter heating is an important consideration
- structures should be designed to withstand strong winds
- in areas affected by snowfall, roofs of shade structures should be pitched to prevent snow build-up
- control of indirect UVR may be an important consideration given the high reflectivity of snow
- use should be made of natural vegetation in areas where it grows well.

## 9. Southern New Zealand

Southern New Zealand includes Southland and the Otago coast.

This climate zone is characterised by cool coastal breezes and a lack of shelter from unsettled weather that moves over the sea from the south and southwest.

Sunshine hours are among the lowest in New Zealand and are often affected by low coastal cloud or by high cloud in foehn wind conditions. However, high temperatures are not uncommon when there are hot northwesterly conditions in summer. Sudden temperature changes can occur when northwesterlies are followed by cold southerlies or southwesterlies. Winters are cold with occasional snowfalls and frequent frost.

- typical summer daytime maximum air temperatures range from 16° C to 23° C, occasionally rising above 30° C
- typical winter daytime maximum air temperatures range from 8° C to 12° C
- annual hours of bright sunshine average less than 1600 hours. However, the midday summer solar ultra violet index (UVI) is often very high. Early autumn and late spring UVI values are normally moderate
- southwesterlies prevail for much of the time about Southland. Northeasterlies are more frequent from Dunedin north.

### Design Considerations

- shade should be accessible from October to February
- access to winter sun is a necessity
- the need for passive winter heating is an important consideration
- protection against cool southwesterly winds required in winter
- structures should be designed to withstand strong winds
- in areas affected by snowfall, roofs of shade structures should be pitched to prevent snow build-up
- control of indirect UVR may be an important consideration given the high reflectivity of snow
- use should be made of natural vegetation.



## 10. Mountainous/alpine regions

This zone includes all areas 800 metres or more above mean sea level, ie all major ski fields, as well as high country/alpine passes, and much of the North Island central plateau.

Mountainous climates vary widely across New Zealand and may be subject to heavy snowfall, high wind, and low temperatures. Periods of rain usually occur in moist northerly quarter airflows, while showery conditions are more likely with southerly quarter airflow. Anticyclones often bring settled weather during summer, and winter conditions may be clear but very cold, with severe frost. The winter through spring period is often more unsettled than the summer through autumn period

- semi-permanent snow and ice fields exist at about 2200–300 metres in the central North Island, and 1800–900 metres in the Southern Alps. These descend to about 1400–500 metres in the North Island, and 1000–100 metres in the Southern Alps during winter
- there are few measurements of annual hours of bright sunshine in these areas. The midday summer solar ultra violet index (UVI) can be extreme. Winter values although low, are augmented by the reflective effect of snowfall.

### design considerations

- shade should be accessible from November to February
- access to winter sun is a necessity
- protection against cool winds required throughout the year
- the need for passive winter heating is an important consideration
- structures should be designed to withstand strong winds
- roofs of shade structures should be pitched to prevent snow build-up
- control of indirect UVR is an important consideration given the high reflectivity of snow.

## Designing for comfort: general principles

In designing comfortable shaded outdoor areas that will be attractive for users, it may be necessary to adapt or modify the microclimate (local climatic conditions) of a site. Different strategies can be incorporated during the design stage of a shade project to counteract the negative effects of the microclimate (yet within the broad context of the prevailing climatic conditions).

A brief discussion of the issues and strategies follows.

**in many locations the penetration of the sun's warmth and light during winter will be necessary for thermal comfort.**

- provide shade which excludes UVR but admits the sun's warmth and light. Translucent polycarbonate sheeting is ideal for this purpose (see Appendix C)
- adjustable devices may suit year-round use
- deciduous trees and other plants will allow warmth and light to penetrate when they lose their foliage. Alternative UVR protection may be needed for outdoor spaces during these periods
- provide alternative external spaces for use in different seasons. Where space is available, this may be an easier and more economical solution
- locate planned summer shade structures so as to not increase winter shade
- planting can be used to form north-facing courtyards or outdoor enclosures for social gatherings or outdoor activities. Plant shelter belts or wind screens to the south, southwest and west, leaving open sunny lawns to the north, adjacent to covered outdoor paving that is warmed by the low winter sun.

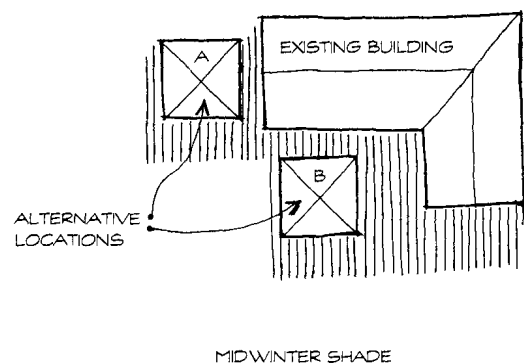
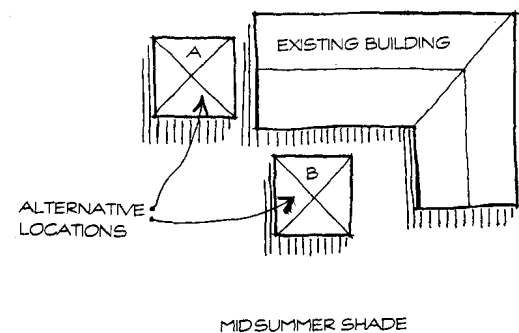

### optimum location of shade structures

**Location B provides good summer shade without creating additional winter shade. Location A will increase winter shade.**

## Designing shade for climate and comfort

- introduce passive solar heating principles while excluding UVR. This can be done by using dark coloured external materials to absorb heat, such as some paving materials. However, ensure shading to paving in summer to limit indirect UVR and prevent the radiation of heat to shaded areas.

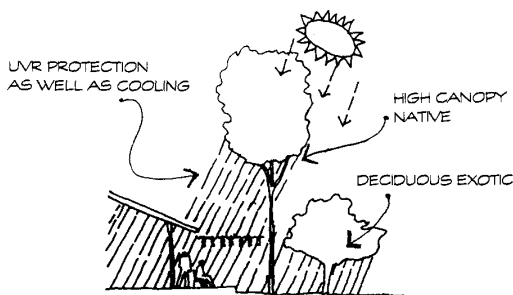

SUMMER –  
DECIDUOUS TREES + VINES, NATIVES WITH HIGH  
CANOPY PLANTED TO NE, NW + SW

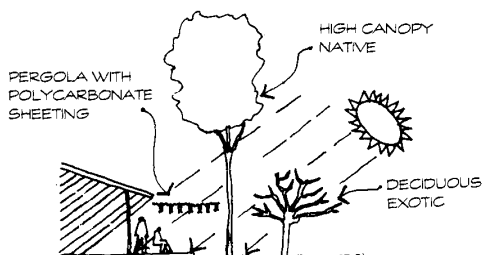

WINTER –  
TRANSLUCENT POLYCARBONATE SHEETING  
OVER PERGOLA SHIELDS FROM DIRECT UVR  
BUT ADMITS WARMTH + LIGHT FROM LOW SUN

**in all locations cooling is recommended during the summer months.**

- design the space to capture any prevailing breezes
- provide shade to the openings of shade structures during summer
- projecting eaves attached to buildings will cool the indoor and outdoor spaces during the summer months. Eaves will also reduce direct UVR and indirect UVR, which could otherwise reflect and scatter off wall surfaces.

**shading of walls and paved areas can significantly increase summer comfort levels**

- when exposed to direct sun, walls and paved surfaces gain heat, which is 'stored' and re-radiated, increasing and maintaining the surrounding temperature. In summer, this can result in overheated, unpleasant outdoor spaces. By shading walls and paved areas, the heating of these surfaces can be significantly reduced and comfort levels enhanced
- glare caused by the reflection of bright sunlight from hard surfaces such as walls and paving can be unpleasant and increase the perception of heat. Shading of such surfaces reduces glare and results in more comfortable outdoor spaces.

### passive solar cooling and heating principles

## Designing shade for climate and comfort

**cross-ventillation will provide relief from excessive humidity and prevent overheating of spaces.**

- where possible, orient openings towards the direction from which cooling breezes come. However, if the requirements of a particular activity do not allow for the ideal orientation, take measures to channel the wind and change its direction
- air flow through the whole structure is due to a pressure difference between the windward and the leeward sides. Wing walls, baffles, or dense groups of bushes positioned on opposite sides of a structure will have the effect of inducing airflow.<sup>5</sup>

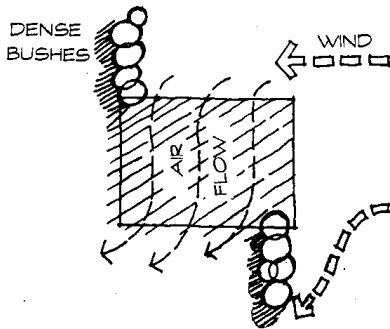

**ways of encouraging cross-ventilation**

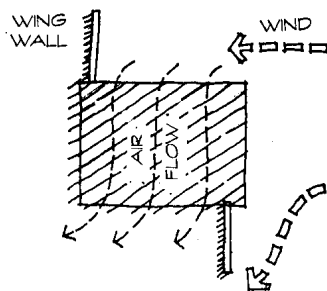

**the exclusion of wind in the cooler part of the year should be considered.**

- observe the direction of any unwanted cold winter winds and provide suitable windbreaks. These may take the form of built attachments (such as screens) or dense tree and shrub 'shelter belts' adjacent to the area requiring protection

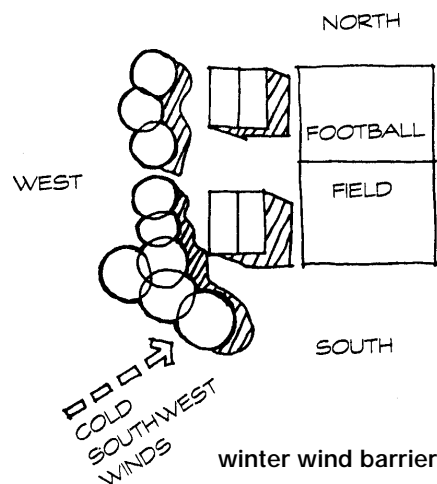

**in many locations, structures must be able to withstand strong winds.**

- gabled or hipped roof forms of pitch 30 produce the best chances for equal pressure spread over the building to avoid eddying and roof lift-off. Tie-down and bracing should be designed in accordance with NZS4203, 1992; Code of Practice for general structural design and design loadings for buildings
- trees located in proximity to a structure can significantly reduce wind loading on the structure
- select materials that are well suited to exposed locations with high winds (eg metal roof sheeting) rather than those inherently more fragile (eg low tensile shade cloth sails).

<sup>5</sup> Szokolay SV. *Climate, comfort and energy - Design of houses for Queensland climates*. Brisbane: The Architectural Science Unit, The University of Queensland, 1991.

# 4 Providing shade

---

There are numerous types of shade systems, incorporating natural or built components, or a combination of these. The following sections describe the major factors and considerations for each of these approaches.

Built shade is designed and constructed of manufactured components, unlike natural shade solutions that use trees, large shrubs, vines and ground covers to block direct UVR and absorb indirect UVR.

A comprehensive shade strategy will most likely incorporate both built and natural shade solutions.

## **Personal shade**

Personal shade includes the beach cabana or umbrella. While cabanas generally offer good protection, umbrellas offer limited protection from indirect UVR, due to their small size and open design. In addition, some products use shade fabrics that do not provide adequate protection from direct UVR.

Nevertheless, the worth of such structures should not be discounted as a means of personal UVR protection, provided other personal protective measures are also taken.

## Natural shade

# Natural shade

---

The use of natural shade can be one of the most effective and aesthetically appealing ways of providing shade. Vegetation offers seasonal variations in perfume, colour and sounds. Many species produce colourful flowers or have attractive foliage or bark, some make good habitats for wildlife and many species can be used to screen unwanted views, give wind protection and provide privacy.<sup>1</sup> Other materials cannot accomplish these things as well as vegetation can.

The use of vegetation for shade also has a number of environmental benefits including:

- less need to use non-renewable resources (used in many building materials)
- energy saved in comparison with built shade systems, which often have high embodied energy (this is the sum of all energy used to produce a material, product or structure including extraction and processing of raw materials, manufacturing, assembly and transportation)
- fewer disposal problems as plants generally act as nutrients during decomposition
- absorption of carbon dioxide in the atmosphere, thereby potentially counter-balancing the 'greenhouse effect'.

The effectiveness of natural shade depends on the density of the foliage. Foliage and timber will block direct UVR, but gaps in the canopy will allow UVR to penetrate. The size of the canopy (of a tree or group of trees) is also an important consideration. The larger the canopy diameter, the greater the opportunity for protection from scattered or reflected UVR. The height of the branches from the ground can also influence the effectiveness of natural shade, with low branches providing better protection.<sup>1</sup>

It should be noted that introducing complete, or even partial shading by vegetation may affect the viability of existing under-storey vegetation. The landscape of shaded areas, as a result, may need to be treated differently to that of non-shaded areas.

## further reading

- Cave, Yvonne and Valda Paddison. *The gardeners' encyclopaedia of New Zealand native plants*. Auckland: Random House, 1999.
- Palmer, Stanley J. *Palmer's Manual of Trees, Shrubs and Climbers*. Queensland: Lancewood Publishing, 1994.
- Yates NZ Ltd. *Yates Garden Guide*. New Zealand: Yates New Zealand Ltd, 1994.

---

<sup>1</sup> Parsons, P et al. The shady side of solar protection. *Medical Journal of Australia* 6 April 1998; 168.

## Landscape planning and design

Vegetation (including trees, shrubs, vines and ground covers) should be considered an essential part of shade planning and site design, as it possesses many qualities which enhance outdoor spaces. In addition, people intuitively associate trees with shade when seeking relief from the heat of the sun. It therefore makes sense to place a high priority on the strategic use of trees and planting to provide shaded areas.

In providing natural shade, there are a number of landscape planning and design issues that should be considered. The main issues are discussed on pages 40 and 41.

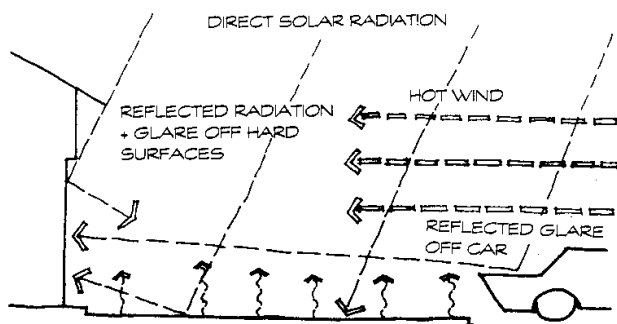

without planting

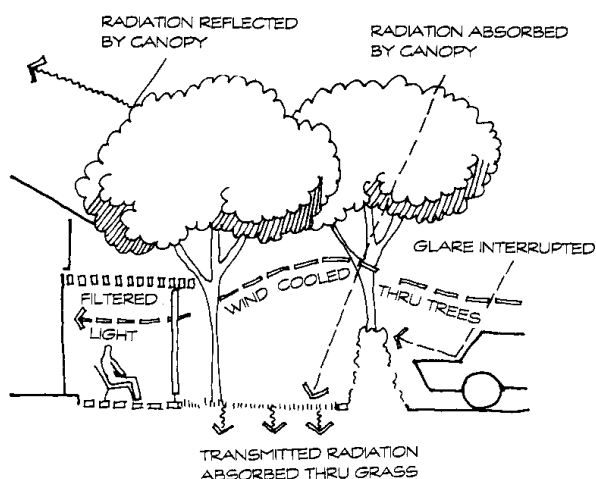

with planting

### note

Most local councils now have positive tree planting policies and special tree preservation orders in place. They also may donate free native trees for planting in public places.

## Natural shade

---

### the surrounding environment

Planting should be consistent with, and sympathetic to, the scale and character of the surrounding environment. Considerations include existing vegetation, townscape character, the cultural heritage value of existing planting, buildings/smaller built items and their settings as well as the landscape identity of the locality.

In some situations exotic species may be the most appropriate selection, for example, in urban areas such as parks and sports grounds. However, where parks and open public areas adjoin a natural waterway, nature reserve or rural countryside, the appropriate local native species should be used.

### local conditions

Local conditions eg soil climate and salinity, will influence the species of plants that will be suitable for a given location. Advice on local conditions should therefore always be sought before selecting plant species for a site. This information can be obtained from regional councils and local nurseries.

### planting patterns and location

It is important to consider site usage patterns when selecting and positioning planting so that shade is provided at the desired time of year. For example, if a venue is used mainly in summer, locate shade trees or vines to provide good summer shade. If a venue is in use year round, deciduous species are more appropriate than evergreens, which may obstruct the transmission of light and warmth in winter.

If you wish to create continuous shade along a pathway, plant trees close enough together to create a visual and physical avenue effect at maturity. If you wish to create shade for areas where people congregate, plant trees in groups with spacing that allows their canopies to overlap at maturity. An alternative approach would be to use a trellis covered with a fast growing, dense foliage climber.

### long-term effects on the built surrounding environment

The long-term effects of the planting on the surrounding built environment should be taken into account. For example, keep large trees away from overhead power lines and underground services, particularly drainage lines. Similarly, the root systems of trees can cause the uplifting of nearby footpaths. The placement of root barriers between the roots and the path is one way of preventing this.

---

## note

See Chapter 3, *Protecting against solar UVR*, for a discussion of the 10 broad climate zones of New Zealand.

## special considerations in relation to site users

If children predominantly use a site for example, it is important to avoid plants that have high toxicity ratings, spiky branches, or that drop fruits or seeds. Trees that are small to medium in size should be selected. Avoid species that are more likely to drop their branches than others. Shrubs that branch clear of the ground can provide play areas under their foliage.

## designing ground surfaces to control indirect UVR

As ground surfaces can be a major contributor to indirect UVR at a site, the selection of surface materials with low UVR reflectance is an important consideration.

Grass is commonly used as a ground surface. However, some of the potential problems associated with this surface are the significant amounts of water required; the need for considerable maintenance (particularly for grass lawns); and problems associated with fertiliser run-off into waterways. It should be noted that water usage for this purpose could be reduced by planting species of trees which will partially shade the grass. Native ground covers, trailing plants or low shrubs can be used to cover large areas which are not required for walking or sitting; or under trees where grass will not grow.

In areas where water is limited and costly, or supply is not assured (or where grass and planting is difficult to maintain) fine loose stone such as decomposed gravel or graded local stone can be used. This approach will still allow for water penetration to the roots of nearby shade trees. In addition, a well-draining compacted surface such as this will not form mud in wet weather, or blow around as dust during dry weather.

## watering and maintenance

It is important to ensure that ongoing maintenance will be available to maintain the effectiveness of the natural shade system or ground cover. Consider if there is an adequate water supply and the possibility of using greywater recycling systems for irrigation.

At the planting stage, it may be worth selecting species that have good water retention properties. Many New Zealand native species have this characteristic. Again, further advice can be obtained from regional councils as well as local nurseries. Native plants will also often require less maintenance than highly manicured lawns and gardens.

### the use of New Zealand native planting

The choice of a New Zealand native tree or an exotic (introduced) species should be guided by a number of criteria including:

- shade needs
- the climate and microclimate
- the physical conditions of the site, eg soil type
- the aspect
- the landscape character of the setting.

Deciduous trees have the advantage of allowing sun through in winter but drop leaves in autumn. One of the benefits of using New Zealand native plant species is that they will also provide a habitat for local wildlife, thus enhancing the biodiversity of an area.

## note

Landcare Research at Lincoln University provides information on toxic plants. There is a small charge. This information is also available on the Landcare website: [www.mwpress.co.nz](http://www.mwpress.co.nz)

## note

See Chapter 2, *Sun facts*, for information on the UVR reflectance of different ground surfaces.

## Built shade

---

Built shade comprises all shade systems that are constructed, as distinct from natural shade. One advantage of using built shade systems, especially permanent systems, is that they can often be used for a number of purposes besides providing shade. For example, a shade structure could be used to collect rainwater for irrigation; or a structure could support photovoltaic cells, (either as a mounted array or as a laminated roofing material) for the generation of electricity.

Built shade systems can be either stand-alone structures, or systems which are incorporated into existing buildings and other facilities. They can be categorised as follows:

- permanent systems
- demountable systems
- adjustable systems.

### Permanent systems

Permanent systems are considered to be those which last for at least 10 years. Their structure commonly comprises a roof with associated supporting structure and sometimes side protection, to reduce the effects of indirect UVR.

It is very important that permanent roofing systems are durable as they need to withstand the harshest of conditions, eg exposure to sun, rain and wind uplift. From an environmental and economic point of view, regular maintenance of these systems is essential to ensure their long life span, thus reducing the need for replacement of materials.

The component parts of a permanent system should either be cheap and easy to replace, or they should have a life span equivalent to that of the main parts of the structure. There is no point having a metal roof with a useful life of 60 years that needs to be replaced after 10 years, because the supporting structure or fixings did not last.

Permanent systems are likely to gain more favourable consideration from funding bodies that provide capital works subsidies.

## Demountable systems

Demountable systems are likely to be a more practical and cost-effective alternative to permanent structures where:

- shade needs are infrequent
- temporary shade is required at varying locations
- a permanent structure is incompatible with the range of activities that take place at a site.

Some demountable systems can be adapted for use in a variety of situations such as above tiered seating as well as over large flat surface areas. Some can be placed on a variety of ground surface conditions such as sand, grass and pavement.

Demountable systems may be designed in modular forms that can be extended or contracted depending on the circumstances. This may consist of a lightweight framework and fabric infills which provide overhead cover, as well as walls where they are required. Alternatively, they may comprise tent-like forms, such as large marquees or lightweight tension membrane structures.

The demountable system should be easy to erect and dismantle. Complex assemblies are time-consuming and increase the risk of incorrect installation. For example, tension membrane structures are quick to erect because the canopy is in one piece. Structures using conventional materials usually take longer to erect because there are more components and fixings.

Demountable systems need to be strong enough to withstand the wear resulting from frequent transportation, assembly and dismantling. The availability of suitable storage facilities is essential to maintain the product in good condition. Their temporary nature means that they are less likely to be subject to vandalism.

## Adjustable systems

Adjustable systems range from very simple devices to those which use sophisticated technology. They offer a high degree of flexibility, allowing protection levels to be modified according to the time of day or season, and to satisfy a variety of user needs. They can be either permanent or demountable.

Adjustable shade systems should be easy and convenient to operate. For example, if operation is time-consuming, difficult or requires specialist attention, use of a device may be discouraged. Systems should also be easy to operate in storms when prompt dismantling of the structure may be necessary.

Components such as pulleys and cables should be corrosion resistant; use of stainless steel is recommended where possible.

Adjustable shade systems are usually attached to a permanent structure and fall broadly into the following two types:

- retractable devices such as canvas awnings
- louvred devices.

### retractable devices

These can cover large areas and can, in some cases, offer rain as well as UVR protection. The most common of these is of the fabric 'roll-out' type. One simple form is the fabric awning, cantilevered or supported by a pergola-like frame. Fabric awnings can also be supported on folding or telescopic arms, which allow adjustments to achieve the required vertical shadow angle. These devices are available in manually operated or motorised form.

Where fabric canopies are tensioned on extension, it is important that they are as taut as possible. This is because movement and flapping of the canopy will reduce the life span of the device. The canopy should be able to be tightened and adjusted as the fabric stretches over time.

It is also important to ensure that the canopy can be adequately stored when retracted. Folding back into a well-ventilated box will extend the life span of the device and prevent accidental damage.

Built shade

There are positive and negative environmental impacts associated with retractable devices.

The negative impacts include those resulting from the manufacture and disposal of plastic and other synthetic materials commonly used in canopy devices. On the other hand, only a small volume of material, and therefore less embodied energy (see Glossary), is required to produce the canopies.

examples of retractable devices

Diagrams A, B and C are examples of linear systems that consist of a folding canopy that is supported or suspended from tensioned wires or a solid frame.

Diagram D is an example of vertical shading that can be used to block reflected and scattered UVR.

Diagram E illustrates a type of retractable awning that is thought to have been used on a large scale to shade seating areas of amphitheatres in Roman times.

Diagram F demonstrates how adjustable awnings can be used to extend overhangs on existing buildings.

Diagram G is an example of a canopy that retracts in one piece; retraction can be achieved by a simple system of pulleys and rope or wire.

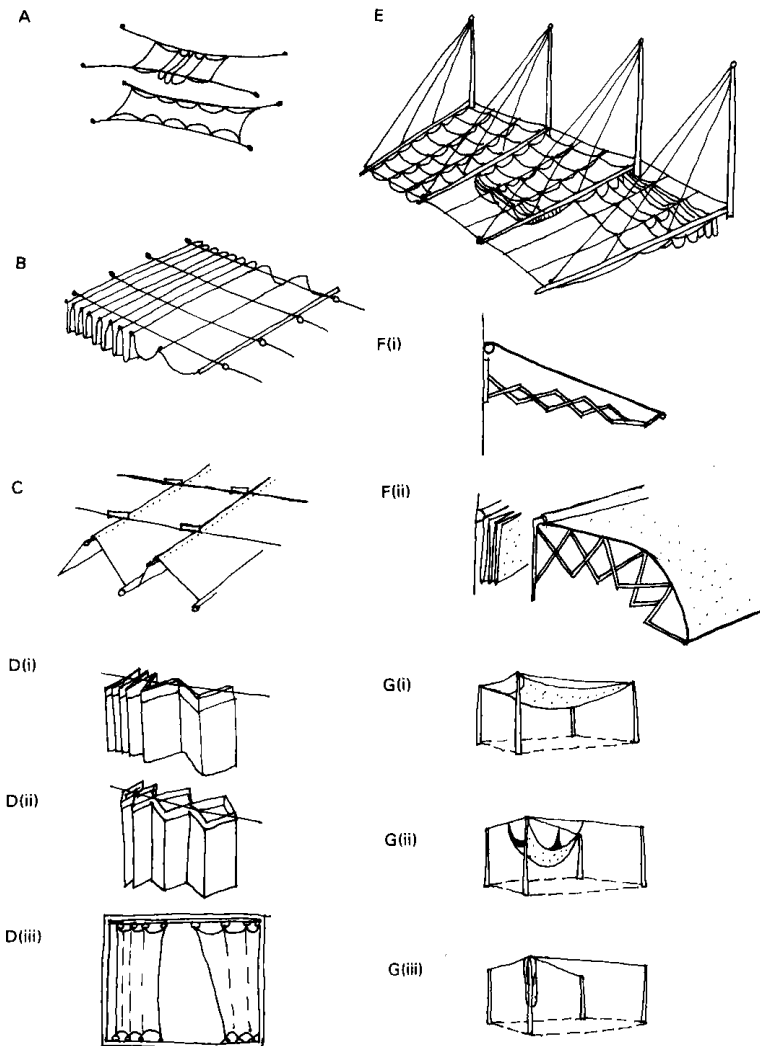

## louvred devices

A range of manually adjusted louvre roof systems are commercially available. These systems offer a high degree of control and flexibility for shading of outdoor areas. They can be adjusted to totally exclude the sun's rays or to create partial shade. Most louvre designs have the added advantage of providing protection against rain.

The louvre blades are usually an aerofoil design, fabricated in pre-painted steel or aluminium. Other materials can also be used for the louvre blades. For example, corrugated polycarbonate sheet could be used in situations where UVR protection and ventilation are required, without excluding warmth and light. Louvres of expanded metal mesh could be used where waterproofing is not a priority.

If the louvres are placed vertically, the louvre wall can be an effective wind deflector, or wind gatherer, in addition to providing protection against direct and indirect UVR.

Also available in the marketplace are louvred roofs which open and close automatically in response to sensors triggered by wind, rain and solar radiation.

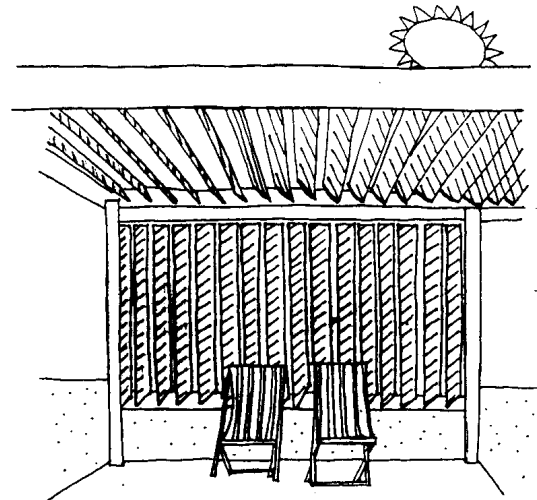

LOUVRES + WALLS CAN BE ADJUSTED TO PROVIDE CONSTANT SHADE DURING THE DAY

## louvred walls and roofs

---

## Components of built shade

Built shade consists of:

- the *supporting structure*, which is required to maintain the shading element in position
- the *primary shading element*, ie the material that comprises the canopy or roof.

The properties of the shading element, such as mass and span, will strongly influence the design of the required supporting structure. For example:

- relatively lightweight materials such as metal or translucent roof sheeting, which are capable of spanning up to 1.2 metres, will require less supporting structure than a roof of terracotta tiles, which are significantly heavier and require supporting battens about every 300mm
- a project that uses structural fabric or shade cloth as the primary shading element will require less supporting structure than metal roof sheeting, as fabrics are lighter and span greater distances when in tension
- solid fabrics such as canvas or reinforced PVC do not allow wind to pass through in the same manner as open-weave shade cloth, and therefore require supporting structures that can resist a much higher level of wind loading.

This relationship between the shading element and supporting structure is significant in determining the functional performance of built shade. Short-span structural systems necessarily result in a high number of supporting columns. While in some situations this may not present a problem, locations such as school playgrounds require shaded areas substantially free of columns. The design brief should define the requirements of the area to be shaded, and the designer should ensure that span characteristics of the supporting structure comply with the requirements of the brief.

The final cost of built shade is also significantly affected by the relationship between the shading element and supporting structure. Selecting a cheap material for the shading element will not be cost-effective if an extensive and costly structure is required to support the selected material. In order to achieve the most cost-effective outcome, the designer must select materials and structural systems that together provide the optimum solution for the brief.







In planning built shade, the required life of the shade structure should be determined and designed for. The post-life use of the materials, ie how they may be re-used, recycled or disposed, should also be considered and designed for.

For all built structures, large or small, it is essential to seek professional structural advice and certification from a qualified structural engineer. This certification is required for building applications and will ensure structural integrity and safety.

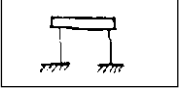
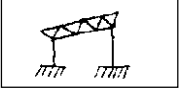
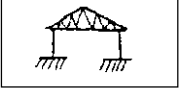
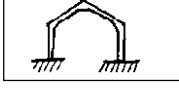
---

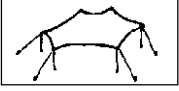
### note

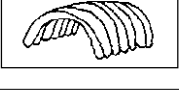
See page 78 for more information on the design brief.

structure	diagram	suitable material	typical span	notes
beams		steel timber concrete	up to 30m up to 15m 7–20m	span is dependent on the type of material used and the design of the beam
girders		steel timber	up to 20m up to 18m (non-laminated)	
trusses		steel timber	8–15m	span is dependent on design of truss
portal frames		steel timber concrete	up to 80m up to 50m 20–40m	an integrated frame, form can be designed to suit need
space frames		steel	dependent on type of system used	
arch structure		steel, timber	large spans of up to 90m	
tension membrane structure	  	steel	dependent on type of system	three main types: 1 cable – cables tension membrane  2 tent – membrane stretched over supports and anchored to ground  3 air – tensioned by air pressure in/under membrane
tension stay structure		steel		roof of structure is partly suspended by same structure

### structural systems for long spans <sup>3</sup>

<sup>3</sup> Elder A. *A handbook of building enclosure*. London: The Architectural Press, 1974.

## supporting structure

The supporting structure required to maintain the shading element in position consists of two elements:

- the footings
- the support system.

The function of the footings is to convey the loads on a structure to the ground. In addition to the load resulting from the weight of the structure, wind can cause significant uplift forces on lightweight structures. For this reason, footings need to be strong enough to hold the structure in place.

There are different types of footings to suit different site conditions. The type chosen is dependent on the superstructure, soil conditions and loading conditions, eg wind.<sup>4</sup> The existence of underground services may influence the type of footing used and its positioning.

The support system, ie columns and beams, holds the roof canopy in place. When selecting a support system a number of factors should be considered including:

- foundation conditions
- span to be covered
- nature and magnitude of loads on the structure, eg wind and weight of building materials
- aesthetics (also in regard to possible future alterations)
- proposed erection method as well as flexibility in use
- fabrication costs
- environmental considerations such as:
  - its embodied energy
  - the lifespan of the structure compared to that of fixtures and canopy materials
  - suitability of support structure for additional uses eg water collection/ photovoltaic array
  - the possibility of re-using the materials at the end of the structure's life (especially for long-life materials), and the ability for material to be disassembled or recycled to minimise waste.

## primary shading element

There are five main categories of materials which can be used for the primary shading element.

### standard building materials

These include:

- metal or tile roofing
- timber
- concrete
- masonry
- other conventional building materials.

Significant advantages over other materials are their assured long life, non-combustibility (except for timber), waterproofing and resistance to vandalism. Given their long life, it is often possible to source these materials second hand, which reduces the need for the manufacture of new materials.

However, standard building materials are characterised by straight line geometry and, unless creatively and carefully designed, can lack aesthetic appeal.<sup>5</sup> They also require a substantial supporting structure.

### rigid translucent materials

These include:

- treated glass
- polycarbonate
- acrylic
- fibreglass sheeting.

These materials block direct UVR while allowing the transmission of heat and diffuse light. They are most suitable for structures intended for winter UVR protection. Being waterproof, they also offer rain protection and can be used to collect water.

It should be noted, however, that many rigid translucent materials, especially the plastic-derived ones, carry a number of environmental costs.

It is therefore recommended that rigid translucent materials only be used where some other

<sup>4</sup> Stroud Foster J. *Mitchell's advanced building construction – The structure*. London: BT Batsford Ltd, 1963.

<sup>5</sup> Davis BT. Shade roof systems for open deck car parks, playgrounds and similar areas. Paper presented to Membrane Structures Association of Australasia Conference; Auckland, New Zealand, July 1–2 1993.

environmental benefit can be achieved, for example, where their use may offset or reduce the need for artificial lighting or heating.

Rigid translucent materials are typically supported at relatively close centres (approximately one metre) on metal or timber framing. Relatively high maintenance is required, both for cleaning and inspections of gaskets and fixings. If correctly installed, sealed and maintained, their life span is medium- to long-term.

#### **structural fabrics**

Examples of structural fabrics include canvas or PVC coated polyester. Being tightly woven, they exclude most UVR. Structural fabrics can be easily demounted and used elsewhere, need less support structure than do permanent fixed systems and require far less material for the shading element itself. Some structural fabrics, however, are non-recyclable and so will contribute to landfill at the end of their life.

Like translucent sheets, structural fabrics are combustible. They require regular maintenance, including cleaning, to retain light transmittance.

#### **knitted or woven fabrics**

Knitted or woven fabrics, such as shade cloth, act as a physical barrier to direct UVR, with little transmittance through the yarn, but 100 percent transmittance through openings in the fabric structure. Different colours and fabric densities provide different levels of protection. For example, a two-tone cloth may have different ratings for each colour. If the material is tightly stretched during installation, the holes in the fabric may expand and allow more UVR to penetrate.

Shade cloths are generally rated in terms of a 'cover factor' that indicates the amount of light blocked. While the correlation between the blockage of light and UVR is high, it is not an accurate measure of UVR protection. However, many manufacturers/suppliers have had their shade cloth rated for UVR transmission. These ratings may vary from less than 50 percent to more than 90 percent.<sup>6</sup>

As the life span of shade cloths is usually short (due primarily to their susceptibility to weathering), they are often used as an interim measure while natural shade is growing. Life span can be extended by designing to allow for progressive tightening to offset stretching.

From an environmental perspective, these materials are generally lightweight so, like structural fabrics, they require less support structure than do permanent fixed systems. However, as it is generally not economically viable to recycle most of these materials (especially those that utilise a number of different materials types, eg PVC coated yarn), their disposal will usually contribute to landfill.

Some important points to note about shade cloth include:

- it may be characterised by poor durability if used in a location subject to windy conditions
- while a relatively inexpensive shade option, care needs to be taken to ensure that the fabric selected provides at least 94 percent protection from direct UVR
- it is often rated as providing 'up to' a certain level of protection, eg up to 95 percent protection. It is necessary to ascertain the actual protection offered as a minimum, not as a maximum.

#### **other materials**

Although shingles, shakes, thatch, brush and lattice are now less commonly used than conventional materials, they have the potential to be used creatively in modern settings. They can provide very effective barriers to direct UVR, are biodegradable and can often be locally sourced, sometimes from the site itself.

With proper design, installation and maintenance, the life span of a structure made from these materials can be greatly increased. However, they are often more labour intensive to install and maintain.

<sup>6</sup> New South Wales Cancer Council.  
*Review of Shade Materials*  
(unpublished).

## Selecting shade materials

When selecting materials for the primary shading element, the following issues need to be considered:

- suitability for proposed design
- ultraviolet protection factor (UPF)
- desired level of light transmission
- desired level of solar heat gain
- waterproofing qualities
- environmental consequences
- wind resistance and structural implications
- ease of replacement
- maintenance requirements
- life span of UVR protective qualities
- particular properties
- relative cost
- compliance with the New Zealand Building Code, eg structures must be structurally durable and also ensure users are not exposed to undue risk from fire.

## UPFs explained

The ultraviolet protection factor (UPF) is a scale developed by the Australian Radiation Laboratory (ARL) to rate the UVR protection provided by materials. The term UPF was chosen to distinguish it from the SPF scheme for sunscreens, though the protective categories are directly comparable. A material's UPF rating is based on the percentage of UVR transmitted through the material.

In 1996, Standards Australia and Standards New Zealand jointly published a standard for sun protective clothing (AS/NZS 4399:1996).<sup>7</sup> The standard describes the testing methods and labelling requirements for UPF-rated clothing. Although the standard applies only to personal clothing, the ARL has stated that for non-clothing items such as tents, awnings and umbrellas, it would be reasonable to attach a label stating the UPF rating of the fabric, as long as it is clear that the rating applies to the fabric only. The ARL states that this may involve a disclaimer to the effect that the UPF rating only applies to the material used in the construction of the item and not to the item as a whole.<sup>8</sup>

The following table is based on the UPF Classification System as it is presented in AS/NZS 4399:1996. The table relates UPF to the percentage of UVR transmitted and absorbed by materials.

UPF range	% UVR absorbed	% UVR transmitted	Protection category described in the Australian/New Zealand standard
15 – 24	93.3 – 95.8	6.7 – 4.2	Good
25 – 39	95.9 – 97.4	4.1 – 2.6	Very good protection
40 – 50+	97.5>	<2.5	Excellent protection

### note

Appendix C contains detailed information on the qualities of different shade materials.

<sup>7</sup> AS/ NZS 4399:1996 *Sun protective clothing – Evaluation and classification*. Standards Australia and Standards New Zealand.

<sup>8</sup> Gies PH. Letter to Australian radiation laboratory clients. October 1996.

## Tension membrane structures

Tension membrane structures (TMSs) are increasingly being used in shade projects. Despite this, they are often the type of structure with which people are least familiar.

Comprising reinforced structural fabrics which are supported at the perimeters with edge cables, TMSs require minimal structural supports. TMSs are a cost-effective option where shade is required for large areas which need to be column-free.

The structural efficiency of a TMS is directly related to the degree of curvature in the fabric. The fabric resists wind-load exerted upon it by a combination of tension and curvature. The tension is usually carried by edge cables which can develop and withstand large tensions.

There are a number of issues relating to TMSs that should be noted:

- due to the large tensions, it is often difficult to attach TMSs to existing buildings, especially those with timber frames or non-reinforced brickwork or blockwork
- if using a complex curved TMS, consideration needs to be given to the shade created to ensure that it is appropriate to the need. For example, the commonly used hypar is a double-curved surface which is formed by twisting a square shape, so that it has two high corners diagonally opposite each other, and two correspondingly low corners. However, the upward sweep of the surface means that, unless the structure is meticulously oriented, little protection is achieved from direct and indirect UVR
- care should be taken to ensure that the curvature of the TMS is suitable for minimising indirect UVR
- regular forms of TMSs may lead to excessive noise levels. Complex or irregular forms, or the use of soft ground surfaces underneath the structure, may help to avoid this
- because TMSs require minimal supporting structures and are lightweight, fewer materials are needed, which is an environmental benefit. However, these materials often have negative environmental impacts associated with their use of non-renewable resources, manufacture and disposal.

For small areas, off-the-shelf TMSs may produce good results, provided that the item is of good quality and that care is taken with orientation.

The design and construction of TMSs is a specialist area. A list of specialist design firms can be obtained from the Lightweight Structures Association of Australasia (see page 155).

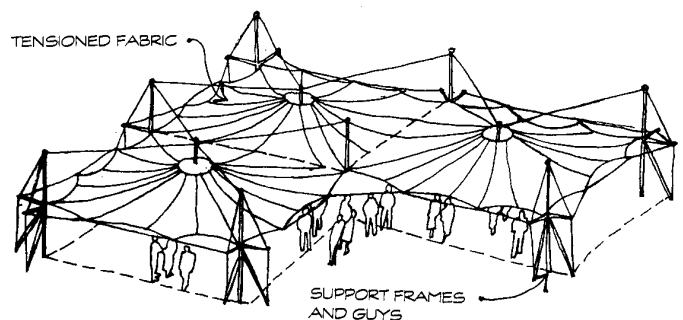

**an example of a tension membrane structure**

### note

See Appendix B for contact details for the Lightweight Structures Association of Australasia.

## Off-the-shelf structures

Off-the-shelf structures are those that are pre-manufactured for assembly on any site. While some purchase contracts provide for supply only, others provide for supply and installation. In the appropriate situation, off-the-shelf structures can provide a readily available, cost-effective method of shade provision.

Prospective buyers of off-the-shelf structures should determine the shade needs of the site prior to approaching suppliers. Unless a Shade Audit has been conducted, it is impossible to determine if an off-the-shelf structure will meet the requirements of the design brief.

It should be remembered that shade suppliers will not necessarily offer independent advice and may not offer advice beyond their own product range. Given that these products are pre-designed, it may also be difficult to find a product that suits all the requirements of the particular site.

If the decision is made to purchase an off-the-shelf structure the following issues should be considered:<sup>9, 10</sup>

- ensure the structure meets the requirements of the design brief:
  - will the structure provide the type of shade required at the right time of day, at the right time of year
  - does it allow for the type of activity taking place near or under it, eg are columns too close to play equipment
  - does it provide an adequate amount of shade for the number of potential users
  - will it affect lighting levels during night-time use
  - does it enhance the attractiveness of the surrounding environment
  - have potential sources of damage been considered, eg vandalism, storms, strong winds

- ensure canopy material provides at least 94 percent protection against direct UVR transmission. Ask to see test results of the material's UVR transmission levels
- check that the level of protection claimed for the product is guaranteed for its lifetime
- ensure the structure does not contribute to hazardous situations, eg placement of guy ropes may result in trip hazards
- ensure the structure is certified by a qualified structural engineer
- inspect examples of previous work done by the supplier. If possible, talk to previous clients about how the product has performed over time
- if the contract is for supply and installation, ensure that the price quoted includes engineering certification of the installed structure including footings.

## Vandalism and other damage

Vandalism can be a major problem, but there are steps shade planners can take to prevent damage to shade structures:

- select hard to damage materials eg corrugated metal roofing
- keep covers high – at least 2.5 metres at low points
- covers over playground equipment need to be higher than any adult standing on the top platform of the equipment
- keep poles one metre away from fences, walls, roofs, trees, and other structures that can be climbed
- separate sails from buildings by cable attachments at least one metre long
- do not place tables and chairs directly under the edges of structures
- try to fade shelters into the natural environment – avoid bold colours and stripes. Sail designs seem to attract the most vandalism
- shelters should be difficult to take down and /or steal
- keep cloth covers away from barbeques to avoid cinders causing holes.

### note

The method for conducting a Shade Audit can be found on page 61.

<sup>9</sup> Alexander-Gabrielson M. *Swimming pools – A guide to their planning, design and operation*. Illinois: Human Kinetics Publishers Inc, 1987.

<sup>10</sup> Brisbane City Council, Department of Recreation and Health. Tender documents for supply and delivery of shade structures (unpublished). 1993.

## Combinations of natural and built shade

## Combinations of natural and built shade

Systems combining both natural and built shade will potentially exhibit the advantages of both. This approach may be particularly appropriate for settings such as picnic areas, school playgrounds and spectator zones at playing fields.

Natural and built elements can be combined to provide effective shade in several ways:

- vegetation can be used to improve the comfort levels afforded by shade structures. For example in summer, plants can be used to channel breezes through a structure. In winter, they can be used to provide windbreaks.
- short-life built structures can be used to provide UVR protection until vegetation planted for shade purposes matures. The structure should have a life of six to 10 years to allow for a reasonable degree of maturity of shade trees.
- structures can be used to support shade-producing vegetation. For example, a vine-covered overhead pergola or a lattice screen, interwoven with climbing plants, can be particularly appropriate during summer.

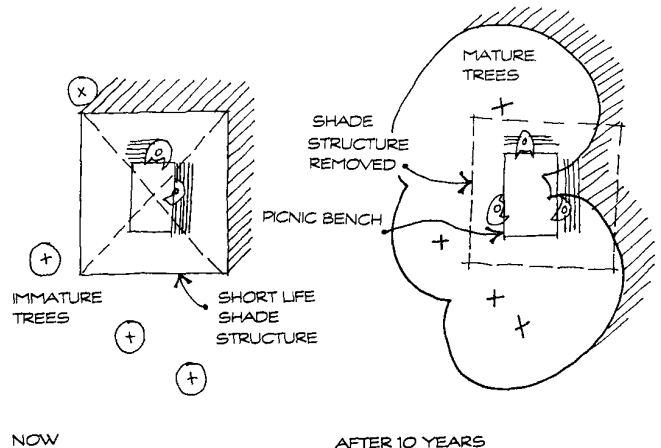

combining structure and vegetation to meet short- and long-term shade needs

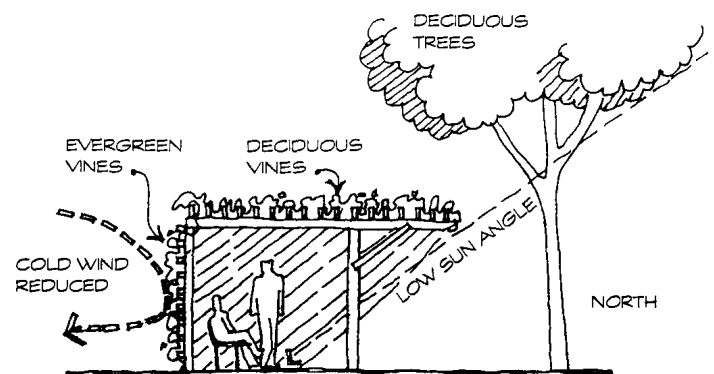

a vine-covered pergola



# 5 The shade project

---

There are three main stages in a shade project:

Stage 1: Planning

Stage 2: Design

Stage 3: Construction.

This chapter suggests the steps and principles that should be considered during each of these stages. Some organisations will have existing procedures for initiatives such as a shade project. If your organisation does not have such procedures in place, the steps and principles outlined in this chapter will be a useful guide. Six case studies have also been included to demonstrate the practice of implementing a shade project.

---

## note

The information contained in this chapter is applicable to both new developments and the redevelopment of existing facilities.

## Planning

# Planning

---

## Steps to effective planning

Effective planning is essential for the success of a shade project. The following points can be used as a guide during the planning process.

### **establish a project team**

A project team should consist of representatives of key stakeholders such as property owners and managers, site users and other interested parties. By establishing a project team you will help to ensure that these stakeholders are involved throughout the project. A project team will also provide the opportunity to draw upon the expertise of its members.

As conflicts can sometimes occur among stakeholders, it is useful to clearly specify how the team should operate, including the roles and responsibilities of members. Conflicts should not necessarily be resolved in favour of the most influential stakeholder or the cheapest solution.

### **consult with other interested parties**

In most situations consultation beyond that which occurs within the project team will be necessary. This is because it may not always be practicable to directly involve all interested parties in the team. It is particularly important that the views and opinions of the people who use the site are considered. This input can be obtained as part of the Shade Audit.

### **conduct a Shade Inventory**

For organisations with a number of sites under their control or a large site comprising a number of precincts, eg hospitals or universities, the Shade Inventory provides the means for prioritising the provision of shade.

### **conduct a Shade Audit**

The Shade Audit will determine the adequacy of existing shade and whether there is a need for more shade. An accurate assessment of need undertaken early in the project will help to achieve shade that is:

- appropriately located
- of appropriate size
- cost-effective.

The method for conducting a Shade Audit follows in this chapter. An example of a completed Shade Audit can be found in Appendix E, p177.

### **prepare a design brief**

The information obtained from the Shade Audit will form the basis of the design brief. The purpose of the design brief is to document the shade needs of the site so that an appropriate solution can be designed. The brief will describe particular requirements of the project, such as the consideration of prevailing climatic conditions and the potential for vandalism.

More detailed information on what information to include in a design brief can be found on page 78.

---

## note

For information on conducting a Shade Inventory see Appendix D.

## note

The method for conducting a Shade Audit follows in this chapter on page 61.

### explore potential sources of funding

There are a number of potential sources of funding for shade projects.

- *Lottery Grants Board New Zealand*

The Lottery Grants Board may provide funding for shade projects on sites that are accessible to the general public for more than 30 hours a week. Secondary schools which run adult education classes may qualify but primary schools would have to show their playground facilities are accessible to the public

- *local councils*

Many councils will provide free trees for planting in public places. Councils in some parts of New Zealand have also contributed funding to shade projects. For more information contact your local council's community funding officer

- *community services organisations, community trusts and pub charities*

Within the community there are a range of community service organisations that will often provide assistance to worthwhile projects, especially where children are to be the beneficiaries. Try organisations such as Lions, Rotary, and community trusts to find you if your project fits into their funding criteria. Approach local pubs that donate profits from gaming machines to community developments

- *Government sources*

Government assistance and funding programmes tend to be subject to regular change but these bodies may provide support for projects that fall within their area of responsibility. Approach local hospitals, public health units, or other government agencies which promote public health

Schools can apply to the Ministry of Education Financial Assistance Scheme, which may provide 50 to 70 percent of the funding needed for a range of projects, including shade structures. Funding decisions depend on the priorities within a school district

- *business sponsorship*

Local businesses or national corporations may be interested in being associated with shade projects at outdoor venues. Commercial benefits flow back to the sponsor through advertising and signage, publicity via media coverage of events and acknowledgment in local editorials for association with UVR protection. There may be tax benefits for sponsoring organisations if support is given in the form of a donation

- *Fund View*

Fund View is a database of funders throughout the country. You enter in details about your organisation and project and the database will come up with a list of potential funders and their criteria. Fund View can be accessed through most public libraries and through the Department of Internal Affairs in central Wellington and their regional offices.

## Design

---

### Key design issues

The design stage will provide solutions to the shade needs as identified in the design brief. Listed below are some key issues to consider during this stage.

#### **consult your local council**

Determine what development controls apply to your site, eg heritage restrictions.

#### **think about the type of shade system that may be appropriate for your site**

Shade systems can be built, natural or a combination of these. In many situations the shade solution will include a combination of natural and built elements. Built systems can be either purpose-built or off-the-shelf. Information on the selection and purchase of off-the-shelf structures can be found in Chapter 4, *Providing shade*.

It is rare that a single solution, eg constructing a shade structure, will provide enough shade to protect against direct and indirect UVR. Usually a series of actions will be required to provide adequate shade in a range of situations at a given site.

#### **consider whether it is necessary to obtain professional assistance from an architect and/or landscape architect**

If you expect that your shade solution will require more than an off-the-shelf structure, it is likely that the expertise of an architect and possibly a landscape architect will be required.

The advantage of obtaining such assistance is that the shade solution is more likely to be designed according to the specific needs of your site. In addition, detailed design plans and documentation will be required by most external funding organisations and if local council development approval is required.

If an architect has been engaged to manage the design and documentation of the project, it is likely that the process of obtaining local council approvals will be facilitated, as architects are familiar with this process. Appendix B contains a list of relevant professional associations.

#### **consider the range of shade options and their likely costs**

At the design stage it is necessary to compare the costs of alternative solutions and to assess whether these are within your budget.

It is important to keep in mind the long-term costs of alternative solutions. The selection of a particular shade option based only on initial costs may not be cost-effective in the long term. Structures that deteriorate quickly or are susceptible to vandalism will contribute to high ongoing maintenance costs. A more substantial structure may provide additional benefits such as rain protection, despite its higher initial cost.

#### **discuss the shade options with relevant stakeholders**

The input of stakeholders early in the design stage may help to ensure that all are satisfied with the end result. You may choose to encourage wider input by publicly displaying sketch plans of the options. Remember to involve the architect in discussions with stakeholders.

If approval needs to be obtained from within your organisation or from the owners or managers of your site, it is particularly important that they have the opportunity to comment on proposed shade options at an early stage of the project.

---

### note

See Appendix C for a comparison of shade materials, including their relative costs and durability.

**determine the preferred shade option**

Once feedback from stakeholders has been obtained, you will be able to determine the preferred shade option. The architect will then be able to finalise drawings and documentation.

Some shade options, eg tension membrane structures, require specialist engineering input. In these situations, the architect will involve other professionals.

**submit the plans to your local council for approval**

In most cases a building consent and project information memorandum must be obtained from the local council before a shade project can commence. Some small buildings, such as simple structures of less than 10m<sup>2</sup>, may not need a building consent and councils have the discretion to waive the requirement for a consent when they have seen plans for the proposed structure. However, the work must comply with the building code<sup>1</sup> even if a consent is not required.

The Building Code<sup>2</sup> does not prescribe construction methods or materials but is designed to ensure any structure will meet the required performances. The code states minimum performance levels such as:

- protecting the health, safety and amenity of people
- protecting other property from damage
- enabling efficient use of energy.

A resource consent may also be needed for construction of a shade structure in some circumstances. A project information memorandum issued with the consent will advise of any such requirements.

The Building Regulations 1992 require that consents for work with an estimated value of less than \$500,000 be processed within 10 working days. However, the clock is stopped on the consent process if Council has to ask the project planners for more details.

A building consent lapses if no work has commenced within six calendar months after issue or if reasonable progress has not been made within 12 calendar months after work has started.

At the end of the work territorial authorities issue a code compliance certificate that signifies they are satisfied the completed building work complies with the requirements of the building code.

You can access technical and legal information about building and building regulations at the Building Industry Authority website: [www.bia.co.nz](http://www.bia.co.nz)

<sup>1</sup> First Schedule to the Building Regulations, 1992.

<sup>2</sup> The Building Act, *Building Approvals* (pamphlet). Building Industry Authority.

## Construction

# Construction

---

The approach taken during the construction stage will be determined by the degree of complexity of the shade design and whether the proposed structure is to be purpose-built or selected from a range of pre-manufactured shade products. If the design incorporates a complicated structure, it may be cost-effective to enter into a 'design and construct contract' with a specialist firm. If a less complex structure or pre-manufactured product is proposed, a standard construction or purchase contract with a builder, manufacturer or supplier will be sufficient.

There are a number of steps that need to be noted during this stage:

- read and understand any contract documents
- develop a checklist system for site visits
- maintain appropriate records
- obtain the builder's construction programme
- obtain the builder's anticipated schedule for progress payment claims
- obtain the builder's insurance certificates
- obtain the manufacturers' guarantees on materials.

The construction phase should be monitored by the architect or a member of the project team.

---

### note

The completion of the construction stage should not be considered to be the end of the shade project. As site usage patterns often change, ongoing monitoring of the adequacy of shade at the site is essential.

## The Shade Audit

The purpose of conducting a Shade Audit is to provide a strategic plan for the provision of sufficient UVR protective shade at a site. This is achieved by:

- establishing the usage patterns at the site
- assessing the quantity and useability of existing shade
- assessing the need for additional shade
- providing recommendations for how to create additional shade (if required) without compromising winter conditions at the site and/or how to modify site usage patterns so that the best use is made of existing shade
- incorporating these recommendations into future development plans for the site and setting a timeframe for their implementation.

### How to conduct a Shade Audit

The Shade Audit comprises four main stages:

- Stage 1: Interviews
- Stage 2: Site fieldwork
- Stage 3: Assessment
- Stage 4: Recommendations.

It is recommended that a project team be formed to help undertake the Shade Audit procedure. Skills that would be helpful to include in the Audit team are:

- the ability to plot measurements to scale
- knowledge of horticulture
- if using the 'projection method' (see page 62), an understanding of sun angles and the ability to plot shade from a theoretical base.

People who have some of these skills include tradespeople, eg a builder or plumber, architects, surveyors, engineers, draftspeople, farmers, horticulturalists, nursery attendants, landscape architects and gardeners.

The Shade Audit should be presented in the form of a written report, documenting the findings from Stages 1, 2 and 3 as well as recommending options for additional shade provision at the site. An example of a completed Shade Audit can be found in Appendix E.

#### note

It is recommended that readers familiarise themselves with the rest of this publication prior to commencing a Shade Audit.

#### note

Owners/managers of large or multiple sites, eg universities or local councils, should conduct a Shade Inventory prior to conducting a Shade Audit. A Shade Inventory provides a procedure for ranking multiple sites (or areas within a site) in order of their need for UVR protective shade. More information on the Shade Inventory can be found in Appendix D.

---

## How to measure shade

One of the critical tasks of the Shade Audit (Stage 2: *Site fieldwork*) is determining the typical existing shade patterns at a site. However, as these patterns are subject to seasonal variations, it is essential that this task be conducted for the critical protection time as well as for a typical winter day.

The critical protection time for a site is the time of day and year when protection from solar UVR will be most important at that site. Factors that should be considered when determining the critical protection time include the site usage patterns (especially times of heaviest usage) as well the levels of UVR.

Information on site usage patterns will be obtained during Stage 1: *Interviews*. It is important that the critical protection time is determined prior to commencing Stage 2: *Site fieldwork*.

An assessment of existing shade can be made by plotting or 'measuring' a site's shade patterns at the critical protection time, which for sites in use throughout the year or mainly in summer, is on the summer solstice, ie 22 December, or thereabouts. An assessment of shade at the same time of day on the winter solstice, ie 21 June, or thereabouts, should also be made so that new shade initiatives can be planned to minimise negative effects on winter conditions at the site. In some situations there may need to be a variation from the solstice dates as:

- the critical protection time for the site may not coincide with the period surrounding the 22 December, eg the critical protection time for a school may be at lunchtime in November because the students are on holidays for most of December; the critical protection time at a sports ground used only for first grade rugby league may be early afternoon in winter
- it may not be convenient to 'measure' the shade at a site during the weeks surrounding 22 December if the observation method is being used.

There are two methods for assessing shade:

- the observation method: where shade is marked on the ground at the site and measured on two occasions (the critical protection time and at the same time on a typical winter day)
- the projection method: which involves the use of sun angles and charts to plot where shade will theoretically fall on two occasions (the critical protection time and at the same time on a typical winter day).

The lay shade planner may prefer to use the observation method, as specialist knowledge of shade projection techniques is required for the projection method. When using the observation method, shade planners must be able to allow for at least a six month period to lapse so that the shade patterns can be assessed at both the critical protection time and in winter.

---

## Stage 1: Interviews

Important background information can be obtained by conducting interviews with site managers, employees and users. The advantage of interviewing representatives from each of these groups is that a range of opinions and observations can be collected for consideration in Stage 3: *Assessment*.

To assist with this stage of the Audit, sample questions for site managers, employees and users have been included on pages 64 to 66 for use in face-to-face or self-completion interview situations. The questions need to be modified to suit the particular issues for different sites or deleted if irrelevant. The information in Chapter 6, *Site Specific Considerations*, will be a useful starting point for the development of tailor-made questions for different sites. So that the areas of a site can be referred to with minimal confusion during the interviews, it is suggested that a site plan (roughly drawn if an existing plan is not available) be used for reference.

Information obtained during the interviews will include:

- the availability of a site plan or survey including the location of services, eg pipes and underground cables, and other relevant site data
- site usage patterns, ie the main outdoor activities undertaken at the site, where they occur and when they occur
- the time of year the site is most in use
- the number of people using the site and their age breakdown
- opinions on the adequacy of existing shade at the site and the need for more shade
- long-term development plans for the site, ie building, landscaping, shade provision
- required performance characteristics of new shade structures, eg rain protection
- other considerations, eg vandalism, areas that cannot be accessed by users.

---

### note

So that information obtained from the interviews is as valid and reliable as possible, it is important that the people selected for interviewing are representative of their group and that enough interviews per group are conducted. As a general rule of thumb, the larger the group or more diverse the group, the more interviews that need to be conducted.

### note

It is also important to confirm the information obtained from the interviews during Stage 2: *Site Fieldwork*, as the perceptions of the interviewees may vary, as can the accuracy of their responses.

## The Shade Audit

### Sample questions for site management eg a school principal

The following questions are indicative of the questions that should be asked of site management representatives. They need to be modified to suit the particular issues for different sites or deleted if irrelevant. The information in Chapter 6, *Site Specific Considerations*, will be a useful starting point for the development of tailor-made questions for the managers of different sites.

- what are the main outdoor activities undertaken at the site? (*Try to be as specific as possible, eg school assemblies, children eating and playing at recess and lunch, educational activities etc*)
- where do they occur? (*Again, try to be as specific as possible, eg school assemblies take place at point X, etc. It may be helpful to mark where different activities occur on a plan of the site*)
- what time/s of day do the activities occur
- what areas of the site aren't available for use eg *out-of-bounds areas*
- generally speaking, what time/s of year is the site most in use
- approximately, how many people use the site on:
  - a) an average weekend day
  - b) an average week day
- what is the approximate age distribution of the users of the site
  - a) babies/toddlers (0–2 yrs) \_\_\_\_\_ %
  - b) children (3–11 yrs) \_\_\_\_\_ %
  - c) adolescents (12–18 yrs) \_\_\_\_\_ %
  - d) adults (19–59 years) \_\_\_\_\_ %
  - e) adults (60+ years) \_\_\_\_\_ %
- in your opinion, how adequate is existing shade at the site, particularly during summer? (*For large or complex sites, it may be helpful to divide the site into zones and then consider the adequacy of shade for each zone*)
- could site usage and/or management practices be modified to optimise the use of existing shade? If yes, how could they be modified? *eg allow access to out-of-bound areas, reschedule outdoor activities, move children's lunch area*
- do you think there is a need for more shade at this site (or any part of it)? If 'yes', what kind of additional shade should be provided and where should it be located
- do you think rain protection is needed at the site? If 'yes', how do you think this should be addressed
- is vandalism an issue that needs to be considered
- are there any barriers to the provision of shade at this site? If 'yes', what are they
- how do you think the site users would feel about the provision of more shade
- what are the long-term plans for the site:
  - a) new building works
  - b) landscaping works
- are there any specific plans for the provision of increased shade at the site? If 'yes', what is planned for the site
- can you make available:
  - a) a site plan
  - b) a survey plan
  - c) services layout
  - d) other site data that may assist?

## Sample questions for site employees eg a school teacher

The following questions are indicative of the questions that should be asked of site employee representatives. They need to be modified to suit the particular issues for different sites or deleted if irrelevant. The information in Chapter 6, *Site Specific Considerations*, will be a useful starting point for the development of tailor-made questions for employees from different sites.

- what are the main outdoor activities undertaken at the site? (*Try to be as specific as possible, eg school assemblies, children eating and playing at recess and lunch, educational activities, etc*)
- where do they occur? (*Again, try to be as specific as possible eg school assemblies take place at point X, etc. It may be helpful to mark where different activities occur on a plan of the site*)
- what time/s of day do the activities occur
- what areas of the site aren't available for use, eg out-of-bounds areas
- generally speaking, what time/s of year is the site most in use
- approximately, how many people use the site on:
  - a) an average weekend day
  - b) an average week day
- what is the approximate age distribution of the users of the site
  - a) babies/toddlers (0–2 yrs) \_\_\_\_\_ %
  - b) children (3–11 yrs) \_\_\_\_\_ %
  - c) adolescents (12–18 yrs) \_\_\_\_\_ %
  - d) adults (19–59 years) \_\_\_\_\_ %
  - e) adults (60+ years) \_\_\_\_\_ %
- in your opinion, how adequate is existing shade at the site, particularly during summer? (*For large or complex sites, it may be helpful to divide the site into zones and then consider the adequacy of shade for each zone*)
- could site usage and/or management practices be modified to optimise the use of existing shade? If yes, how could they be modified, *eg allow access to out-of-bounds areas, reschedule outdoor activities, move children's lunch area*
- do you think there is a need for more shade at this site (or any part of it)? If 'yes', what kind of additional shade should be provided and where should it be located
- do you think rain protection is needed at the site? If 'yes', how do you think this should be addressed
- is vandalism an issue that needs to be considered
- do you think there are any barriers to the provision of shade at this site? If 'yes', what are they
- how do you think the site users would feel about the provision of more shade?

## Stage 2: Site fieldwork

### Sample questions for site users eg school children/students

The following questions are indicative of the questions that should be asked of site user representatives. They need to be modified to suit the particular issues for different sites or deleted if irrelevant. The information in Chapter 6, *Site Specific Considerations*, will be a useful starting point for the development of tailor-made questions for the users of different sites. Questions will need to be rephrased according to the age of the interviewees.

- which of the following age categories do you fit into:
  - a) 5–11 years
  - b) 12–18 years
  - c) 19–59 years
  - d) 60+ years
- do you make use of the available shade when you are at this place:
  - a) all of the time
  - b) most of the time
  - c) some of the time
  - d) occasionally
  - e) never
- are there areas of the site that cannot be used? If 'yes', what do you understand is the reason?
- in your opinion, how adequate is existing shade at this place, particularly during summer?
- do you think there is a need for more shade at this place (or any part of it)? If 'yes', what kind of additional shade should be provided and where should it be located?
- are there any shaded areas at this place that you prefer not to use? If 'yes', why?
- do you think rain protection is needed at this place? If 'yes', how do you think this should be addressed?

This stage of the Audit involves the collection of site data, as well as the confirmation of information obtained during the interviews. As both observation and detailed measurement need to be made, it is recommended that two site visits be conducted:

- the first, at a time of typical site use so that observations of usage patterns can be made and the critical protection time confirmed (This step could coincide with Stage 1: *Interviews*.)
- the second, at a time when users will not be inconvenienced so that measurements can be made.

If the observation method is being followed, additional site visits may need to be conducted so that shade patterns are measured at both the critical protection time and at the same time of day during winter.

The main tasks for the site fieldwork are outlined on pages 67 to 75. Most tasks need to be completed regardless of which shade measurement method is being followed. This is indicated by a 4 appearing under both headings for the particular task. Some of the tasks, however, are relevant for only one of the shade measurement methods, ie either the observation method or 66 projection method. Where this is the case, a 4 will appear under the heading to which the task applies, and a 8 will appear under the heading to which the task does NOT apply.

The site fieldwork will require the use of a measuring tape and camera.

### note

It is crucial that any data and information collected during this stage of the Audit is accurate and complete. This is because it will be used as core information in the Assessment stage of the Audit.

Observation Method	Projection Method	Tasks	Comments
<b>observing site usage patterns</b>			
4	4	1 Pay particular attention to the type and location of outdoor activities and where people tend to congregate.	The purpose of this task is to confirm the information gained from the interviews.
4	4	2 Consider if people gather in a location because it is the only place where they can undertake a particular activity, or if the activity could be moved to a shaded area.	The observations should be made at a time of typical site use. If there are any discrepancies between your observations and the information obtained during the interviews, consider whether they should be discussed with some of the interviewees.
4	4	3 Make a note of whether people are using the available shade.	
<b>preparing the site plan</b>			
4	4	1 Obtain a copy of an accurate, scaled site plan (if available): <ul style="list-style-type: none"> <li>confirm the accuracy of the site plan by making some random measurements and checking that all buildings appear on the plan</li> <li>if all the buildings do not appear on the plan, measure, locate and plot the measurements to scale.</li> </ul> <p><i>If a site plan is not available:</i></p> <ul style="list-style-type: none"> <li>firstly, draw a freehand plan of the site and record the overall dimensions of the land, as well as the length and width of buildings and their distance from each other and from the site boundaries</li> <li>draw an accurate site plan by plotting the measurements to scale.</li> </ul>	The purpose of this task is to prepare the site plan for the site investigation and shade measurement stages of the Audit. If an accurate site plan is available, the time-consuming task of comprehensively measuring the site and drawing up a plan to scale will be avoided.
4	4	2 Mark on the site plan the direction of north, noting whether it is 'magnetic' or 'true' north.	See example sketch on page 70.  Refer to the Glossary for an explanation of 'true north' and 'magnetic north'.

## The Shade Audit

Observation Method	Projection Method	Tasks	Comments
<b>investigating the site</b>			
4	4	1 During the site fieldwork, take photographs of the following for your records: <ul style="list-style-type: none"> <li>• the site and patterns of usage</li> <li>• trees (to assist identification)</li> <li>• existing shade structures</li> <li>• problem areas, eg unshaded seats</li> <li>• shade opportunities.</li> </ul>	A photographic record of the site will assist in Stage 3: <i>Assessment</i> as it may help to reinforce data and prompt memory. Photographs can also be helpful for presentation purposes as they illustrate particular aspects of a site.
4	4	2 Record the location of the following items on the site plan with a name or number: <ul style="list-style-type: none"> <li>• buildings, eg assembly hall, canteen or B1, B2, etc</li> <li>• other built items, eg pools, play equipment etc</li> <li>• existing shade structures, eg S1, S2.</li> </ul>	See sample plans on pages 70 and 72.
4	4	3 Divide the outdoor areas between buildings and other built items into zones, based on the site usage patterns.	Refer to Chapter 6 for information on the typical usage patterns for different sites.
		4 Record each zone on the site plan with numbers, eg Z1, Z2 or names, eg assembly area, lunch area, etc.	See sample plans on pages 70 and 72.
4	4	5 Record on the site plan any significant ground level changes, ie in excess of 600mm.	This task will help with the planning and location of new shade structures.
4	4	6 Record on the site plan any special site conditions that may impact on the design of new shade structures, eg emergency access points, topography.	
4	4	7 Make a note of the ground surface/s within each outdoor zone, eg concrete, grass. Pay particular attention to ground surface changes within a zone.	These tasks will assist with the assessment of the degree of reflected UVR at a site. See sample on page 71.

Observation Method	Projection Method	Tasks	Comments
4	4	8 Make a note of the buildings' surfaces/ finishes (wall and roof) as well as their roof shapes. Pay particular attention to walls that may reflect high levels of UVR, due to their material/finish and the direction they face, ie north or up to 45° either side of north.	See sample on page 71.
8	4	9 Measure the heights of buildings at the eaves and ridges.	You do NOT need to do this if you are using the observation method.
8	4	10 Measure the length, width and height of existing shade structures.	You do NOT need to do this if you are using the observation method.
4	4	11 Record on the site plan, the location of trees or groups of trees: <ul style="list-style-type: none"> <li>• <i>for small or simple sites</i>, it may be possible to number each tree, eg T1, T2, etc</li> <li>• <i>for large or complex sites</i>, it is easier to nominate areas of planting, eg P1, P2, etc, than to number individual trees.</li> </ul>	See sample on page 72.
4	4	12 Note details of each tree or planted area as follows: <ul style="list-style-type: none"> <li>• the species, or within each planted area, the predominant tree/shrub species</li> <li>• estimated height (metres)</li> <li>• maturity, eg three years old</li> <li>• condition (particularly any problems)</li> <li>• the density of the canopy (see page 74)</li> <li>• the estimated canopy diameter (metres)</li> <li>• whether it is deciduous or evergreen.</li> </ul> <p>Also, for planted areas, assess any particularly significant individual trees/ shrubs within the group, eg a large tree with dense foliage and a wide spreading canopy, or any that are situated by themselves.</p>	<p>This task will require some horticultural knowledge. So that existing natural shade is correctly documented, try to include a person with such expertise in your Shade Audit team, eg landscape gardener, nursery attendant.</p> <p>See sample on page 73.</p>

The Shade Audit

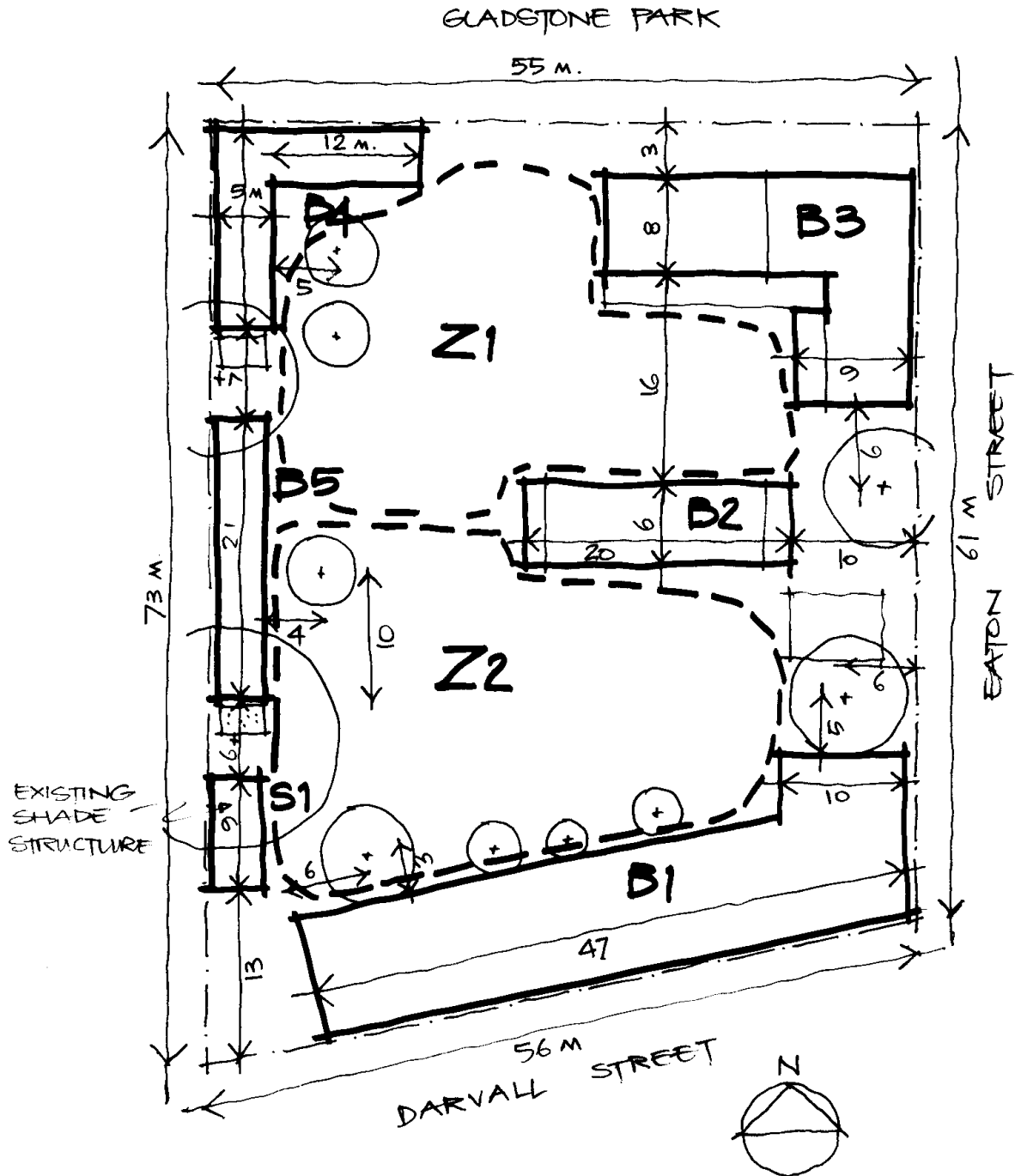

rough sketch of a school site showing dimensions, building numbers and outdoor zones

sample  
ground surfaces/finishes

ZONE N°	DESCRIPTION	PREDOMINANT SURFACE
Z1	OPEN PLAYGROUND	BITUMEN
Z2	OPEN PLAYGROUND	GRASSED LAWN.

sample  
buildings: wall and roof surfaces/finishes; roof shape

BUILDING N°	DESCRIPTION	WALLS	ROOF	ROOF FORM.
B1	MAIN BUILDING	BRICK	TILES	PITCHED GABLE
B2	INFANTS BLOCK	PAINTED BRICK	CORR. IRON	PITCHED GABLE
B3	ASSEMBLY BDG.	SANDSTONE	CORR. IRON	PITCHED GABLE
B4	AFTERSCHOOL	BRICK	TILES	PITCHED
B5	TOILET BLOCK	PAINTED BRICK	CORR. IRON	PITCHED.
S1	SHADE STRUCTURE	-	CORR. IRON	FLAT.

The Shade Audit

GLADSTONE PARK

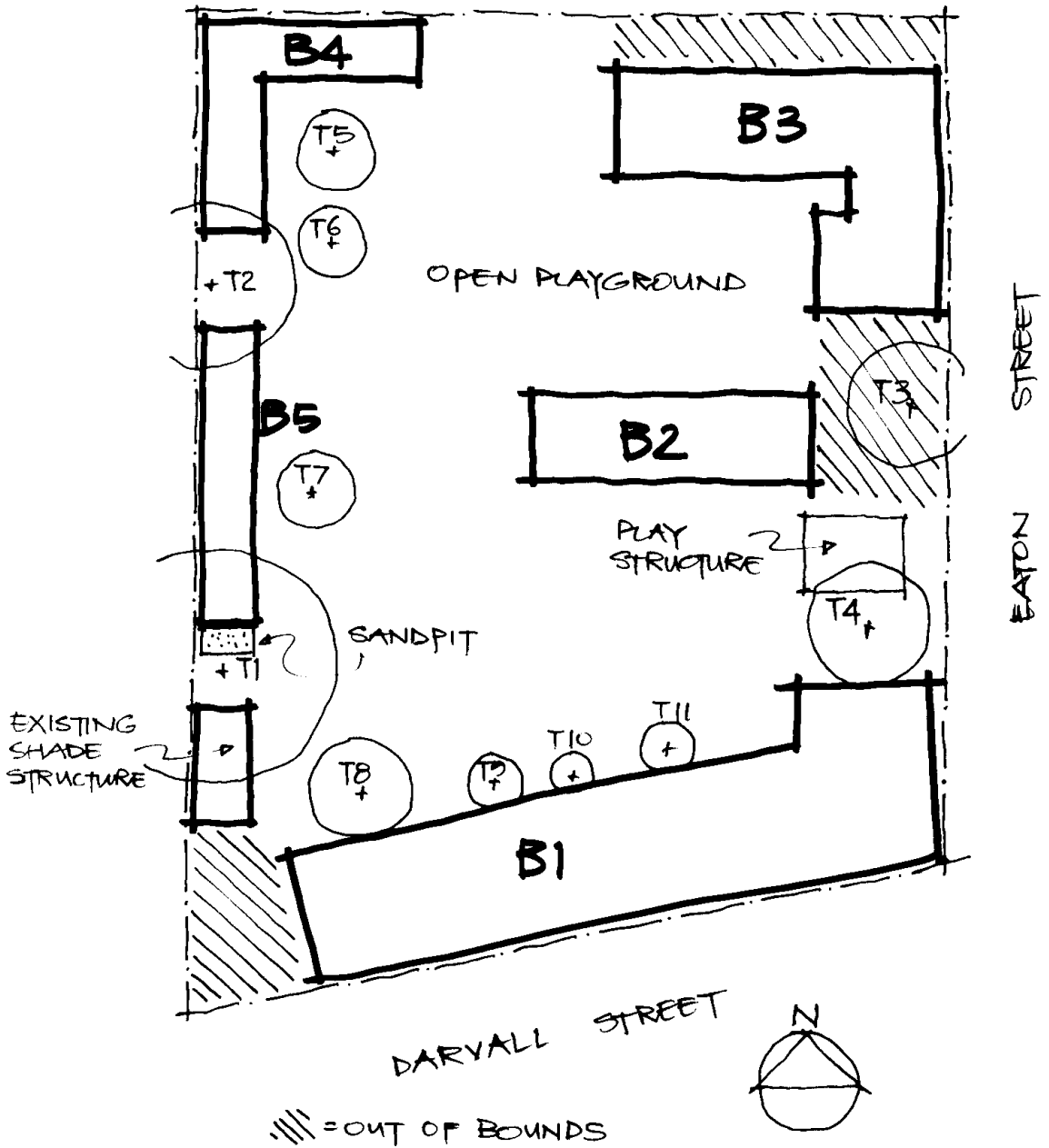

rough sketch of a school site showing site details, trees, building numbers and outdoor zones

## sample

tree identification, assessment and measurement

TREE NO	SPECIES	HEIGHT (M)	MATURITY	CONDITION	CANOPY DENSITY	CANOPY DIAMETER	DECIDUOUS/ EVERGREEN
1	PLANE TREE	20	MATURE	GOOD	HEAVY	17M	DEC
2	LILYPILLY	10	MATURE	AVERAGE	HEAVY	11M	EVER
3	BRUSH BOX	10	MATURE	GOOD	HEAVY	8M	EVER
4	EUCALYPT	15	OLD	POOR	MEDIUM	9M	EVER
5	TALLOWWOOD	10	SEMI	GOOD	HEAVY	6M	EVER
6	TALLOWWOOD	10	SEMI	GOOD	HEAVY	6M	EVER
7	BRUSH BOX	8	SEMI	GOOD	HEAVY	6M	EVER
8	BLACK WATTLE	8	OLD	POOR	HEAVY	7M	EVER
9	EVERGREEN ALDER	6	SEMI	AVERAGE	HEAVY	4M	EVER
10	FIDDLEWOOD	3	SEMI	AVERAGE	HEAVY	3M	EVER
11	EVERGREEN ALDER	6	SEMI	AVERAGE	HEAVY	4M	EVER

## The Shade Audit

---

### canopy density guide

The canopy density guide will help you to assess the level of UVR protection provided by different trees.

View the tree canopy against sky and compare with illustrated leaf/canopy patterns. Estimate which pattern of sky and leaves most closely approximates the observed canopy.

#### heavy – over 90% UVR protection

Good protection from direct UVR. Protection from indirect UVR will depend on canopy size and where a person is positioned under the canopy. Suitable for long-stay use if personal sun protection measures are also used.

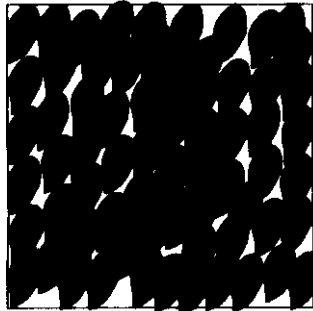

#### medium – around 60% UVR protection

Filtered shade provides low levels of protection from direct and indirect UVR. Suitable for short-stay use only. Personal sun protection measures should also be used.

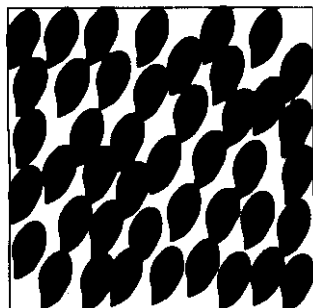

#### light – less than 30% UVR protection

Poor protection from direct and indirect UVR. Suitable for transit shade only.

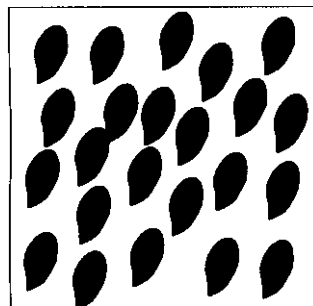

Observation Method	Projection Method	Tasks	Comments
<b>Measuring existing shade – ‘observation’ method</b>			
4	8	1 Mark the shade patterns at the site on the ground using chalk, rope or a similar method (at the critical protection time as well as at the same time of day during winter).	This task must be conducted twice, once at the critical protection time and again during winter (typically 21 June).
4	8	2 Measure the dimensions of the shade outline.	
4	8	3 Plot the data to scale on the site plan.	Refer to pages 180 and 181 in Appendix E for an example of the completed task.
<b>Measuring existing shade – ‘projection’ method</b>			
8	4	1 Project the shade patterns at the site using sun angles (at the critical protection time as well as at the same time of day during winter).	This task is necessarily technical as it involves the projection and drafting of theoretical shade patterns and will require a detailed knowledge of sun projection techniques.
8	4	2 Plot the data to scale on the site plan.	Refer to pages 180 and 181 in Appendix E for an example of the completed task.

## Stage 3: Assessment

By this stage of the Shade Audit, the shade patterns at the critical protection time and in winter will have been plotted to scale on the site plan. The next stage of the Audit involves an assessment of the quantity and useability of existing shade and the need for additional shade.

There are a number of tasks that need to be completed. They are as follows:

### **consider the likely impact of *future tree growth* on the amount of shade at the site**

Will tree growth significantly alter the amount or distribution of shade?

If it will, how long will it take before significant changes occur? It may be necessary to consult a person with horticultural expertise for information regarding tree growth rates.

### **Consider *the amount of existing shade* at the critical protection time and compare this with the need for shade, taking into account the additional shade that may result from tree growth**

Is the amount of shade adequate for the number of people using the site?

How much additional shade is likely to be required to provide an adequate amount of shade for the number of people using the site?

Are there opportunities to better utilise or access existing shade?

### **consider whether the *location of existing shade* is appropriate, given the usage patterns at the site**

Are there areas of use where shade is inadequate?

Is adequate shade provided in areas of non-discretionary use, ie areas where people are compelled to be? (In non-discretionary use areas, eg numbered seating in grandstands at sports grounds, most of the patrons should be able to access shade, particularly during summer.)

Are there adequate opportunities for people to find shade in discretionary use areas, ie areas where people choose to go? (In discretionary use areas, eg grassed spectator areas at sports grounds, at least 50 percent of the patrons should be able to access shade, particularly during summer.)

Are there priority areas for further shade provision, given site usage patterns?

Should/can existing shade be re-located to be more compatible with site usage patterns?

### **if additional shade is required, consider where it should be located, keeping in mind the site usage patterns and winter shade patterns**

Are there locations that will allow additional summer shade to be achieved without creating excessive shaded areas in winter?

Are these locations compatible with site usage patterns?

### **consider the *impact of indirect UVR* on the site and possible means of reducing its impact**

Are some areas of the site likely to have high levels of indirect UVR as a result of surface finishes, eg smooth paving, reflective walls?

Can these surfaces be modified to reduce the likelihood of indirect UVR?

Can other measures be adopted to minimise the impact of indirect UVR?

## note

During Stage 3: *Assessment* it is important to draw upon the data collected during the interviews and site fieldwork. The site specific issues and recommendations in Chapter 6 should also be considered.

## Stage 4: Recommendations

The recommendations stage of the Shade Audit involves documenting the potential strategies to achieve a site's shade requirements. Specific recommendations should be made regarding each of the following:

- the *desired shade goal/s* for the site, eg increase shade over passive playground areas (where children eat their lunch, where assemblies are held)
- the *strategies* for achieving the goal/s, including:
  - revising site management practices, eg accessing shaded 'out-of-bounds' areas, rescheduling outdoor activities
  - optimising the use of existing shade, eg relocating activities or outdoor equipment to shaded areas, removing low branches from trees to allow access
  - creating new shaded areas (include information on the performance characteristics of the proposed shade, ie amount of additional shade that is needed, where it should be located, the time/s of day and year that the shade is required; also think about the range of shade options, both natural and built, that may be appropriate and their likely costs)
  - minimising the effects of indirect UVR on the site (or areas within it), eg modifying surfaces by planting ground covers or covering concrete with synthetic turf, designing shade structures that protect from indirect UVR
- the *desired timeframe* for achieving the shade goal/s for the site
- the *project management options* for achieving the shade goal/s, for example:
  - organising a working bee with volunteers to relocate seating and lop low branches off trees
  - engaging an architect to design a shade structure that can be constructed by semi-skilled volunteer labour
  - engaging an architect to manage the design and construction stages of the shade project
  - asking a project team member with an interest in landscaping to recommend a tree planting strategy
  - inviting shade manufacturers to submit a proposal for supply and installation of a shade structure
  - implementing a staged shade project (to allow for fundraising).

A Shade Plan should be prepared (based on the site plan), indicating where the above strategies will be implemented. An example of a Shade Plan can be found on page 185 in Appendix E.

The recommendations and the Shade Plan should be incorporated into the design brief, a document that is provided to professionals such as architects and shade manufacturers. A comprehensive design brief will help to ensure that the shade solution/s for a site (off-the-shelf or custom made) will meet a site's shade requirements. More information on preparing a design brief can be found on the following page.

### note

Because of the effects of indirect UVR and climate, it is rare that the shade goal/s for a site can be achieved by a single action, eg the construction of a shade structure. More commonly, a series of actions will be required to address the complex factors present at most sites.

---

## A design brief for your shade project

The purpose of the design brief is to set the parameters within which the designer or supplier must work.

You are aware of your needs, you know the special aspects of your site and you may have skills within your group that could be used during the project. The Shade Audit will have provided you with a range of shade options for the site, and you should have determined which of these you prefer.

The design brief is intended to convey this information to the person you have selected to assist you with designing the project. Information required for the design brief includes, but is not limited to, the following points:

### site information

Provide information regarding the site, preferably in the form of a site plan, showing:

- location of proposed project
- location of underground services if known
- emergency or other access routes that must be maintained
- any particular site constraints that may impact upon the design, eg future projects, ground conditions.

### performance characteristics

Set out your requirements with regard to the performance of the shade:

- area to be protected by shade
- critical protection time
- type of shade required, eg built or natural, permanent or demountable
- need for rain shelter
- nature of activities in the proximity of the project, eg children at play, vehicle movements
- special climatic conditions
- likely vandalism threat
- maintenance needs
- longevity.

### financial and human resources

- provide information about the budget for the project.
- advise if there are skills within your organisation or group that may be used in the design or development of the project. If skilled labour, eg carpenters or sail makers, is available, this is likely to influence the choice of construction method. Voluntary unskilled labour during construction will reduce the project cost.

## Shade project case studies

---

- **Waikawa Bay Primary School (Marlborough Sounds)**

This study demonstrates how primary schools can raise funds and erect simple shade structures. It highlights the need for effective planning to combat problems such as vandalism.

- **Balmain Public School**

This study demonstrates the benefits of the Shade Audit as a planning tool and a means of raising funds. It also exemplifies the wide-ranging strategies that can be adopted to provide more protective shade.

- **Baradine Multipurpose Courts**

The Baradine study demonstrates how fostering support in the community can overcome apparent obstacles such as limited funding.

- **Campion College (Gisborne)**

This project shows how schools can erect low-cost shade structures, using volunteers from the school community.

- **Springwood High School**

This study demonstrates the benefits of collaborating with the community in a project initiated by the students.

- **Western Suburbs Olympic Pool (Unanderra)**

The Unanderra study shows how a shade project can achieve additional objectives to that of providing shade.

---

## Waikawa Bay Primary School

Waikawa Bay is a semi-rural primary school near Picton. A major shade project was started after surveys of parents had highlighted the lack of shade at the school as a major concern. Silk trees had been planted but these trees were not large enough to provide enough shade for about 100 children attending Waikawa Bay.

Parents were involved in the shade project through the PTA and the Board of Trustees, although technical aspects and construction were handled by the school property management company, School Support. The school decided to erect cloth shading to cover tiered seating up a five metre, 45° slope. A rectangular shade cloth runs parallel with the slope. Another shade cloth covers a flat area.

The school had to apply for a building permit because of the size of the structure. Lowering the height of the supporting metal poles was recommended because Waikawa Bay is exposed to strong southerly winds, as well as lighter prevailing northerly winds. However, lowering the structure means teenagers are able to climb on top of the cloth by climbing nearby trees and use the edges of the structure as a climbing support. The school is in the process of capping the poles to raise the height of the shade structure.

The structure provides summer shade for assemblies, outdoor learning, lunchtime and for children who bring books out of an adjacent library. The cloth is taken down in the cooler winters. Waikawa Bay School says the structure meets most of its shade needs but believes schools need to design structures that have a minimal risk of vandalism.

---

## Balmain Public School

Balmain Public School is located in an inner city suburb of Sydney. It has approximately 300 students. In 1992, the School Parents and Citizens' (P&C) Solar Protection Committee began a comprehensive effort to increase the level of UVR protection available in the school grounds.

A professionally conducted Shade Audit had shown that only 15 percent of the playground area had shade, of the total shade, only 61 percent was usable and out-of-bounds areas prevented the use of a number of existing areas of shade.

The Audit resulted in the setting of three goals; reducing direct and indirect UVR at the site, making better use of existing summer shade and creating an additional 400 m<sup>2</sup> of summer shade.

### re-organisation of outdoor areas

Discussions with school staff resulted in students being able to use previously out-of-bounds areas. A large disused incinerator that had been situated under a shade tree was removed. Existing garden beds were modified to permit access to shaded areas and to allow the planting of additional trees. The P&C paid the local council for the erection of a protective fence in adjacent parkland to increase the shaded area available to the students.

### fundraising

Part-funding for the shade project was successfully sought from the then New South Wales Department of School Education. A campaign to raise the balance of the required funding was launched in the local business community. A sponsorship proposal was distributed throughout the community seeking a specific amount from each of ten local businesses for the erection of a shade/rain shelter to protect the children of Balmain School. Sponsors were offered:

- publicity in local newspapers and school newsletters
- promotion in the local community
- guest of honour status at the official opening of the new shade facilities
- tax deductibility for the sponsor's donation through the establishment of a building fund
- the opportunity to contribute to a reduction in the incidence of skin cancer in the Australian community.

### construction of a shade structure

After obtaining quotes from a number of suppliers, a company was commissioned to construct a structure. Construction costs were minimised by negotiating with the company to allow volunteers (parents) to contribute unskilled labour.

This multi-faceted shade project has resulted in a significant increase in protection from UVR for an at-risk population group.

## Baradine Multipurpose Courts

Baradine is a small township in Western New South Wales. In 1996, the Baradine Community Health Centre became aware of the need for shade at the town's main community sporting facility, the Baradine Multipurpose Courts. The facility, often used for school sporting events, provided little shade for spectators and participants.

Staff at the Community Health Centre sought local community involvement and support for a proposal to provide adequate shade at the site. Extensive consultations were conducted with stakeholders including those from the local municipal council, schools, sporting and health groups. Residents' opinions on the proposed shade project were sought via a survey printed in the weekly newspaper and distributed through the local newspaper, chemist and schools. Respondents to the survey overwhelmingly supported the proposal.

After the consultation phase, an application for a Skin Cancer Prevention Grant was submitted to the Western District Public Health Unit, and a grant of \$1,000 secured.

Following another round of consultation with stakeholders, the type of structure to be erected was determined by the project's building committee. It was apparent from the consultation that insufficient human and financial resources would be available for future repairs and maintenance. The committee opted for a durable, low maintenance structure with framework, roof and sides constructed of galvanised iron.

Comfort is a major consideration in Baradine's hot, dry climate so the northeast and southwest ends of the structure were left open to take advantage of prevailing winds. Trees and other vegetation were planted around the structure to shield it against the sun's rays and add to the cooling effect.

Community involvement in the project resulted in significant cost savings. A local builder donated his time to design the structure, prepare costs and arrange purchase of all materials. Labour was donated by the local Skillshare programme.

With community support, Baradine now has a cost effective shade structure that provides UVR protection for users of its sporting facility.

## Campion College

Campion College is a secondary school in Gisborne where summer temperatures can reach 37° and winters are relatively warm and sunny. A request for more shade came through the Parent Teacher Friends Association which had received feedback from pupils and parents about the lack of shade, especially in the canteen areas where pupils ate their lunch.

The College is built in an E shape with two quads which are enclosed on three sides. Each quad is about half the size of a football field and grassed in the middle. The canteen is in one of the quads but lack of shade was hampering efforts to encourage the pupils to eat their lunch in this area.

Funding for the project was raised by running pizza days and sausage sizzles. The project cost \$7,360, with the shelters costing \$3,657. Costs were kept down by using volunteers from the school community to build the shade structure, under the supervision of a parent who was a builder.

Two cloth shade structures measuring about six metres by seven metres were erected by parents, along with seating and raised gardens. Seating was also built along the south side of the building to provide more shady seating for students. A building consent was needed for the work.

The college reports the shade structure meets its needs of providing shade for the pupils. The new area enhances the design of the college which has been built in a Pacific style for coolness. Classrooms are on the second floor and overhang the quads, a design which also provides some shade during summer.

Deciduous trees planted before the shade project got underway are starting to provide substantial shade in other parts of the college. Campion College believes providing shade is more effective than trying to force teenagers to wear hats.

Mild Gisborne winters mean the cloth can stay in place all year. One problem not identified at the outset of the project is that the cloth is not waterproof so the shade area can not be used on warm wet days.

Vandalism has not been a major problem although Campion College reports one of the cloth shades has been stolen. The cover is insured but in future the covers may be padlocked onto the structure.

## Shade project case studies

### Springwood High School

Springwood High School is a medium-size school located in the lower Blue Mountains, west of Sydney. In early 1996, students at the school submitted a request through their Students' Representative Council for more shade in the school grounds.

The school responded by developing links with organisations it believed would be interested in supporting a shade project for the school. A joint working party was formed that included teachers and student council representatives, along with representatives from Springwood Hospital, the Wentworth Centre for Health Promotion and the New South Wales Cancer Council.

The goals of the working party were to:

- plant trees in the school grounds
- erect a shade structure by the end of 1997
- raise students' awareness of the need to use shade facilities
- incorporate skin cancer prevention into school policies.

To achieve these goals a number of fundraising activities took place. A seeding grant of \$1,000 was successfully sought from the local Area Health Service and \$3,000 was provided by the Wentworth Centre for Health Promotion. The announcement of the seeding grant was used to generate publicity in the local media, which led to further community interest.

In addition to the seeding grant, \$3,200 was raised through activities such as a guessing competition and an arts and crafts fair, which were organised by the School's P&C Association. The school itself also provided \$3,000.

Students, parents and other interested members of the community donated a significant amount of time to the project. Members of the Faulconbridge Residents' Association who live in the vicinity of the school, made a commitment to keep an eye on the proposed shade structure in an effort to prevent possible episodes of vandalism.

The contributions of all those involved came to fruition in October 1997 with the completion of a shade structure in the school grounds. As the provision of natural shade had been the other key component of the strategy, a total of fifty shade trees were also planted.

The strong motivation and commitment of the working group, students, teachers and the local community resulted in a significant increase in the amount of available shade at the school.

---

## Western Suburbs Olympic Pool, Unanderra

The Western Suburbs Olympic Pool, administered and operated by the Wollongong City Council, is located at Unanderra in the Illawarra region of New South Wales.

In 1995, the local swimming club proposed that solar heating be introduced to heat the pool water for more comfortable swimming during autumn and winter. Around this time, local community health officers conducted a 'Cool Pool' sun protection awareness raising programme as well as shade audits of council pools. In addition, the council had been receiving an increasing number of requests for shade from pool patrons.

The potential to provide both solar heating and shade in the one project was quickly recognised by council planners, who put in place a comprehensive strategy to achieve both objectives. Given the nature of the site, it was decided that built shade would be the preferred option.

Media publicity for the project generated significant community support. This support was a major factor in raising \$226,000 from the following sources:

- a swimathon organised by the swimming club raised \$22,500. Students from local schools were sponsored to swim laps of the pool. A local bus company donated its staff and buses to transport the students to and from the pool
- a grant of \$20,000 from the New South Wales Department of Sport and Recreation
- a bequest, also for an amount of \$20,000, specifying that the funds be used for the benefit of children attending the pool
- an allocation of \$163,500 from Wollongong Council's capital works budget.

The resulting structure has fulfilled all expectations. Built of timber framing with a colourbond roof, it provides a total of 825m<sup>2</sup> of shade as well as holding 800m<sup>2</sup> of solar absorber panels. Its U-shape provides shade to three sides of the pool. According to staff, the shade provided by the structure is regularly used by pool patrons.

This case study demonstrates how built shade systems can be adapted to serve more than one purpose. It also exemplifies the benefits of involving and gaining the support of the wider community in local shade projects.

# 6 Site specific considerations

---

The recommendations provided for each site in this chapter are necessarily 'rules of thumb' as shade planning is an emerging discipline and is subject to ongoing study. Those involved in shade projects should adapt the recommendations with discretion, ensuring that particular characteristics of a specific site are considered.

As each chapter of this publication contains vital information for effective shade planning, it is suggested that Chapters 1 to 5 be read before the site specific considerations.

# Early childhood services

---

Early childhood services typically include centre-based, mobile child care, family day care and home-based care services. While the focus of this section is on the centre-based service, many of the issues discussed will be of interest to other service types.

Early childhood services can play a significant role in the prevention of skin cancer. There are a number of reasons for this:

- part of the critical period for sustaining damaging levels of solar UVR exposure occurs during early childhood
- children attend these services up to five days per week throughout the year, often during the high UVR risk period of each day
- children frequently play outdoors while attending these services.

In addition, all services are required under Part 3 of the Education (Early Childhood Centres) Regulation 1998 to have policies and procedures to ensure the health and safety of the children in their care.

While the provision of sufficient UVR protective shade is an important element of an early childhood service's sun protection strategy, it will not guarantee total UVR protection. Shade should be one component of a comprehensive strategy which also includes personal protection measures, ie wearing sun protective clothing, hats, sunscreen and sunglasses. Care should also be taken to minimise the time spent outdoors between 11am and 4pm during summer, when daily UVR levels are generally at their peak.

It should also be noted that in regard to the staff employed in early childhood centres that the Health and Safety in Employment Act 1992 requires employers to identify and control the risk faced by workers required to work outdoors. An assessment should be made of the solar UV radiation to which workers are likely to be exposed and steps should be taken to try and minimise any risks. Workers should also take responsibility to look after their own health.

---

## note

It is essential that an assessment of existing shade be made before the planning and design of additional shade commences.

Chapter 5 contains a step by step approach to conducting a Shade Audit, as well as advice on managing a shade project.

an example of shade at an early childhood centre

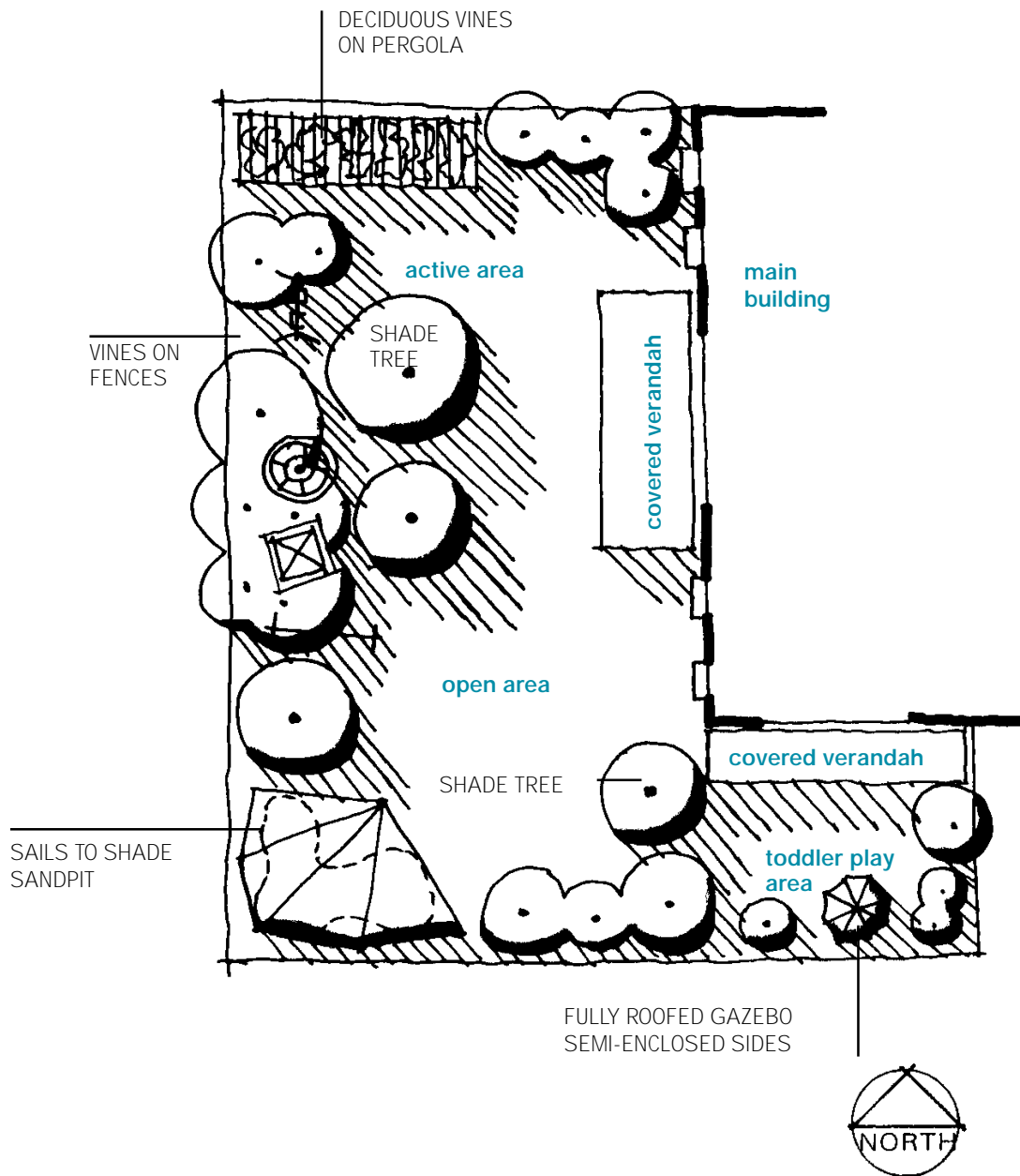

## planning and design issues

Many of the following considerations refer to concepts discussed in more detail in other parts of this publication. For this reason it is recommended that readers familiarise themselves with the content of Chapters 1 to 5 as well as Appendix C, before considering the specific issues for early childhood services.

### service types

Shade planning and design for each service type will be influenced by the number of children in care and the size of the outdoor play space.

### project team

Ideally, representatives from management, teaching staff and parent groups as well as relevant professionals, eg architects, landscape architects, should be involved. This will help to ensure that the need for shade is considered within the context of other issues and requirements.

### existing shade

Plans should be made to optimise the use of existing shade before additional shade is considered, eg play equipment could be re-located to a shaded area, low branches could be removed from trees to allow children to play underneath.

### site usage patterns

It is important to take into account the usage patterns at the site, including the type of activities that occur and the time of day they occur. Within the outdoor space at a centre-based service there are usually a number of distinct play areas including:

- an open area for gross motor skills, eg running
- a quiet area for focused play, eg a sandpit
- a formal quiet area for contained play, eg finger painting
- an active area for busy physical play, eg climbing
- a transition zone between indoor and outdoor areas, eg a verandah.

If babies and toddlers are being catered for, there should be a separate play area for them, within the outdoor space.<sup>1</sup>

While each of these areas has its own shade requirements, the design approach should aim to create shade that complements and reinforces the ordering of different play areas and movement paths.<sup>2</sup>

### climatic conditions

It is important to take into account the overall characteristics of the particular climate zone in which the service is situated, as well as any local conditions, eg strong wind. When these are understood it is possible to use design strategies to modify adverse conditions. The effects of local conditions, particularly salt (in relation to corrosion) and wind, also need to be considered in the selection and design of shade structures as well as the selection of tree species.

### seasonal considerations

Care needs to be taken to ensure that new shade initiatives do not intensify winter conditions at the site.

Summer shade provision should minimise UVR levels as well as reduce heat and light. Winter shade provision should allow for transmission of sufficient levels of heat and light. The use of adjustable shade systems and/or deciduous vegetation may provide greater flexibility.

<sup>1</sup> New South Wales Department of Community Services. *Best practice guidelines in early childhood physical environments*. Sydney, 1996, 91.

<sup>2</sup> Queensland Health and Department of Architecture, University of Queensland. *Shade for young children*. Brisbane, 1997, 17.

**indirect UVR**

Indirect UVR is an important factor to consider when designing built shade structures and selecting ground surfaces for outdoor play spaces. Coarse and/or soft surfaces, eg brick pavers or grass, will reflect less UVR than hard and/or smooth surfaces, eg trowelled concrete. Existing surfaces can be modified if they reflect high levels of UVR.

**aesthetics**

Shade design should aim to be aesthetically pleasing as well as practical. Generally, an approach which combines both built and natural shade is preferable.

Using a variety of forms of shade will help to create a different identity for each area and a more interesting play space. Visually attractive components include:

- coloured sails
- structures with textured sides or spaces to view through
- structures that support flowering vines
- trees, shrubs and vines (deciduous and evergreen) with different seeding, flowering and fruiting habits (ensure that these are not potentially hazardous to children).

Using a variety of tree and shrub species will also help to create a more interesting and stimulating environment for the children.

**supervision**

Children need to be readily viewed by staff at all times for both safety reasons and teaching purposes. Examples of designs that may hinder supervision include shade structures with solid and/or opaque sides and low placement of overhead sails. Trees and shrubs also have the potential to obstruct supervision if they are inappropriately located.

**approval**

Local councils will usually require development approval for built shade structures.

**natural shade**

Natural shade should be a major element of shade provision within an outdoor play space. Trees with dense foliage and wide spreading canopies provide the best protection, although leaves can create ongoing maintenance problems for sandpits.

Species should be selected to suit local soil and climatic conditions as well as the character of the surrounding environment. Generally, they should be planted on the north, northeastern and northwestern sides of the play space. Root barriers and subsoil drainage will help to ensure that adjacent paved areas are not damaged by tree roots.

Dense shrubs also have the potential to provide shade. They should be planted around the perimeter of the site so they do not obstruct supervision. Pruning shrubs on the underside may allow for shaded play nooks to be created underneath.

Shrubs and trees selected for the play space should be non-toxic and should not be dangerous in other ways. For example, avoid species that:

- have seed pods or stone-fruit (a potential choking hazard for children under five years of age)
- attract bees
- have thorns or spikes
- are known to cause adverse health effects such as asthma and skin irritation.

Also note that some species of trees have a tendency to drop their branches.

If natural shade is the long-term favoured option for areas within the site, short-life built structures, ie with a lifespan of six to 10 years, can be used until trees planted for shade purposes mature.

## Early childhood services

---

### **safety**

It is important to ensure that shade structures do not create safety hazards. Support systems, eg upright posts, should be clearly visible and ideally have rounded edges and/or padding. They should be placed so as to minimise intrusion into play and circulation areas. Where possible, guy ropes should be avoided, as they may be a trip hazard. In addition, vertical barriers at the sides of shade structures should be designed to prevent children using them for climbing.

### **scale**

Scale is an important issue to consider when designing shade for early childhood environments. For example, what may seem a comfortably sized space for an adult may be overwhelming to a small child.

This issue however, needs to be balanced with the need for adult access to children's play spaces. For this reason, a head clearance height of approximately two metres is recommended for shade structures. If vertical barriers are to be placed at the side of structures, they should allow for views through at child height, rather than adult height.

The useability of the floor space underneath the structure is another issue that needs to be considered. It should be of a sufficient size and shape to allow children to gather or play actively underneath.

### **demountable structures**

Demountable shade structures should only be used to supplement more permanent forms of shade. Some demountable structures, eg umbrellas, offer limited protection. Umbrellas also provide limited group space underneath and may be unstable during windy conditions.

### **off-the-shelf structures**

In the appropriate situation, off-the-shelf structures can provide a readily available, cost-effective shade solution. However, unless a Shade Audit has been conducted, it is difficult to tell if they will meet the site's shade requirements. If the decision is made to purchase an off-the-shelf structure, the issues outlined in Chapter 4 of this publication should be considered.

### **rain protection**

It may be desirable to incorporate built structures into the design that offer both UVR and rain protection.

### **minimum regulation size play spaces**

In outdoor play spaces built to minimum regulation size, it is not always possible to use the variety of shade solutions suggested in this publication. The placement of a permanent or adjustable shade system over a major part of the play space may be the only viable solution.

### **existing services**

The location of shade structures and planting should take account of existing services, eg drainage, power lines, gas, water.

### **an additional resource**

The Queensland publication *Shade for young children* is a useful additional resource. Full reference details can be found under *further reading* at the end of this section. See page 93.

---

## recommendations and considerations

The recommendations below are minimum shade guidelines for centre-based services across New Zealand during summer. It is acknowledged that it may not be possible in the short term to implement all these recommendations due to funding constraints. However, medium-term plans should include improvements to summer shade provision as a priority.

Specific recommendations for winter shade have not been made due to differences in the prevailing climatic conditions across New Zealand during winter. However, the UV index is rarely above one or two in most parts of New Zealand in winter and risk levels are low.

---

### open area

Partial shade is recommended, especially over grass which needs some sun for growth.

Natural shade is the most appropriate option.

Consider arranging planting in clusters so that groups of children can access shade.

Deciduous trees will allow for penetration of warmth and light to the play space during winter.

---

### quiet area

Shade during October to March is recommended, particularly over sandpits.

A permanent shade system is the most appropriate option.

The need for winter warmth and light should be considered.

---

### formal quiet area

Shade during October to March is recommended.

Consider using a combination of built and natural shade.

The need for winter warmth and light should be considered.

---

## Early childhood services

---

---

### active area

Shade during October to March is recommended, over fixed play equipment and areas where children play for extended periods of time, eg a digging patch.

Moveable equipment used for active play, eg climbing frames, should be placed in the shade. Consider using a combination of built and natural shade.

The need for winter warmth and light should be considered.

### *fixed play equipment*

Safety is a major consideration for shade provision over fixed play equipment.

Shade structures over fixed play equipment should not have footholds or grip surfaces which would allow for climbing.

The roofline of the shade structure should extend at least 500 millimetres beyond the edge of the deck of the play equipment, to prevent child access on to the roof.

The roof of the shade structure should allow for a minimum head clearance height of two metres above the deck of the play equipment.

Tree trunks and the upright posts of shade structures should be located a minimum distance of two metres away from the most fully extended part of the play equipment, eg the side of a climbing platform or the end of an extended swing arc. This will ensure sufficient freefall zones.

Any shade structure in the play area should be designed with reference to AS/NZS 4486.1:1997 (see *further reading*, page 93.)

---

### transition zone

Verandahs will provide permanent shade as well as rain protection.

The angle of the roof and the extent of overhang should be designed to maximise shade for the major part of the day, especially during summer.

The width of the verandah should be a minimum of four metres to allow for shaded play space underneath.

Roof materials should be selected to minimise heat build-up during summer. The roof should be insulated (with at least a ceiling cavity, and preferably with insulation material too) and airflow points should be provided.

---

---

transition zone continued	<p>Terraces, with a deciduous, vine-covered pergola or an adjustable shade system, will provide seasonal shade. Some canopies will also provide rain protection.</p> <p>Retractable or louvred shade canopies should be easily adjustable, ideally by one person at ground level.</p> <p>A combination of fixed roof verandah and terrace spaces may be desirable for some services.</p> <p>Vertical pull-down blinds at the side of a verandah or terrace can provide additional protection from UVR when the sun is low in the sky.</p>
<b>baby/toddler area</b>	<p>Shade during October to March is recommended, with UV protection recommended throughout the year.</p> <p>Consider using a combination of natural and built shade.</p> <p>The need for winter warmth and light should be considered.</p>

---

## further reading

- AS/NZS 4422:1996 *Playground surfacing – Specifications, requirements and test methods*. Standards Australia and Standards New Zealand.
  - AS/NZS 4486.1:1997 *Playgrounds and playground equipment Part 1 – Development, installation, inspection, maintenance and operation*. Standards Australia and Standards New Zealand.
  - ECVV Working Party. *Plan it! Guidelines for planning, early childhood outdoor supervised play environments in NSW*. Kidsafe, New South Wales, 1996.
  - NSW Department of Community Services. *Design and planning – Checklist for a new child care centre in New South Wales*. Sydney, 1996.
  - Queensland Health and Department of Architecture, Queensland University. *Shade for young children*. Brisbane, 1997.
  - Walsh P. *Early childhood playgrounds – Planning an outside learning environment*. Alberts Park: Robert Andersen and Associates, 1988.
-

## Schools

# Schools

---

Schools can play a significant role in the prevention of skin cancer. There are a number of reasons for this:

- part of the critical period for sustaining damaging levels of solar UVR exposure occurs during the school years
- students are at school up to five days per week, throughout most of the year and during the high UVR risk period of each day
- students often spend a significant amount of time outdoors while at school.

In addition, schools have a duty of care to provide a safe environment for students.

While the provision of sufficient UVR protective shade is an important element of a school's sun protection strategy, it will not guarantee total UVR protection. Shade should be one component of a comprehensive strategy that also includes encouraging the use of personal protection measures, ie wearing sun protective clothing, hats, sunscreen and sunglasses, as well as implementing sun awareness education. Outdoor activities should be rescheduled (where possible) outside the hours of 11am to 4pm daylight saving time, when daily UVR levels are generally at their peak.

It should also be noted that in regard to school staff, that the Health and Safety in Employment Act 1992 requires employers to identify and control the risk faced by workers required to work outdoors. An assessment should be made of the solar UV radiation to which workers are likely to be exposed and steps should be taken to try and minimise any risks. Workers should also take responsibility to look after their own health.

---

### note

It is essential that an assessment of existing shade be made before the planning and design of additional shade commences.

Chapter 5 contains a step by step approach to conducting a Shade Audit, as well advice on managing a shade project.

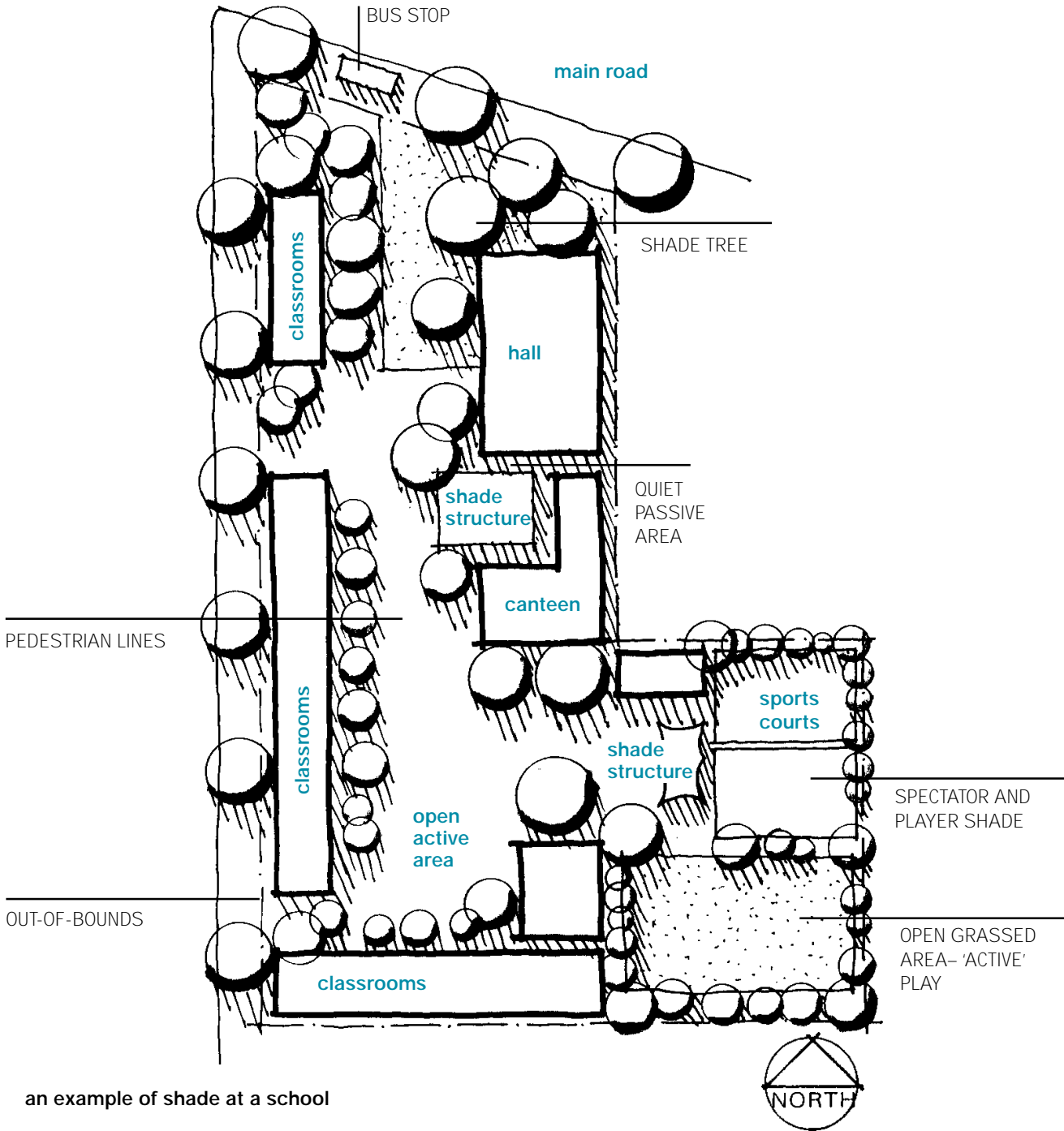

---

## planning and design issues

Many of the following considerations refer to concepts discussed in more detail in other parts of this publication. For this reason it is recommended that readers familiarise themselves with the content of Chapters 1 to 5 as well as Appendix C, before considering the specific issues for schools.

### project team

Ideally representatives from school executive, teaching staff and parent groups as well as relevant professionals, eg architects, landscape architects, should be involved. This will help to ensure that the need for shade is considered within the context of other issues, including long-term development plans for the site.

If the school grounds are used by community groups on the weekends or during school holidays, it may be appropriate to liaise with them during the project, particularly if it will cause disruption to the areas they use.

### student participation

Students should be consulted and involved throughout the shade project, eg they could undertake certain tasks in the Shade Audit.

### existing shade

Plans should be made to optimise the use of existing shade before additional shade is considered. For example, fixed seating could be re-located to a shaded area, low branches could be removed from trees to allow access, playground use could be reviewed to permit access to shaded out-of-bounds areas.

### site usage patterns

It is important to take into account the usage patterns at the site, particularly the times of day different activities occur. Students' play and social patterns also need to be considered, eg primary school children are generally required to eat lunch in class groups while secondary students tend to gather in small discrete clusters.

The outdoor areas of schools usually comprise:

- active playground areas, eg for ball games and free play
- passive playground areas, eg for eating lunch and socialising
- canteen areas
- bus stop areas.

These areas are connected by pedestrian links. While each area has its own shade requirements, they should be considered within the context of the whole school site.

Some schools also have specialist facilities, for example swimming pools, tennis courts, sports fields or agricultural areas.

### active vs passive use

Sufficient shade should be provided for students to undertake active outdoor activities such as free play, physical education classes and sport, particularly during summer.

Sufficient shade should also be provided for eating and socialising, lining up (especially after recess and lunch) and assemblies, particularly during summer. These activities could be undertaken in covered outdoor learning areas, active playground areas or specific passive-use areas.

### climatic conditions

It is important to take into account the overall characteristics of the particular climate zone in which the school is situated, as well as any local conditions, eg strong wind. When these are understood it is possible to use design strategies to modify adverse conditions. The effects of local conditions, particularly salt (in relation to corrosion) and wind, also need to be considered in the selection and design of shade structures as well as the selection of tree species.

**seasonal considerations**

Care needs to be taken to ensure that new shade initiatives do not intensify winter conditions at the site.

Summer shade provision should minimise UVR levels as well as reduce heat and light. Winter shade provision should allow for transmission of sufficient levels of heat and light. The use of adjustable shade systems and/or deciduous vegetation may provide greater flexibility.

**indirect UVR**

Indirect UVR is an important factor to consider when designing built shade structures and selecting ground surfaces for playground areas. Coarse and/or soft surfaces, eg brick pavers or grass, will reflect less UVR than hard and/or smooth surfaces, eg trowelled concrete. Existing surfaces can be modified if they reflect high levels of UVR.

**aesthetics**

Shade design should aim to be aesthetically pleasing as well as practical. Generally, an approach which combines both natural and built shade is preferable. Using a variety of tree and shrub species will also help to create a more interesting environment.

**approval**

Local councils will usually require development approval for built shade structures.

**natural shade**

Natural shade should be a major element of shade provision within a school. Trees with dense foliage and wide spreading canopies provide the best protection.

Species should be selected to suit local soil and climatic conditions as well as the character of the surrounding environment. Root barriers and subsoil drainage will help to ensure that pavements are not damaged by tree roots. Dense shrubs also have the potential to provide shade.

Avoid shrubs and trees that:

- are toxic
- have seed pods or stone-fruit
- attract bees
- have spikes or thorns
- are known to cause adverse health effects such as asthma or skin irritation.

Also note that some species of trees have a tendency to drop their branches.

If natural shade is the long-term favoured option for areas within the site, short-life built structures, ie with a lifespan of six to ten years, can be used until trees planted for shade purposes mature.

Local nurseries and councils may provide trees at no cost or at a discount.

**safety**

It is important to ensure that shade structures do not create safety hazards. Support systems, eg upright posts, should be clearly visible and ideally have rounded edges and/or padding. They should be placed so as to minimise intrusion into play and circulation areas. Where possible guy ropes should be avoided, as they may be a trip hazard. In addition, vertical barriers at the sides of shade structures should be designed to prevent children using them for climbing.

**vandalism**

Vandalism can be a major problem but there are steps shade planners can take to prevent damage to shade structures. See *Built shade*, page 52.

## Schools

---

### **demountable structures**

Demountable shade structures should only be used to supplement more permanent forms of shade. Some demountable structures, eg umbrellas, offer limited protection. Umbrellas also offer limited group space underneath and may be unstable during windy conditions.

### **off-the-shelf structures**

In the appropriate situation, off-the-shelf structures can provide a readily available, cost-effective shade solution. However, unless a Shade Audit has been conducted, it is difficult to tell if they will meet the site's shade requirements. If the decision is made to purchase an off-the-shelf structure, the issues outlined in Chapter 4 of this publication should be considered.

### **rain protection**

Schools often lack sufficient wet weather shelter. Built structures that offer both UVR and rain protection can help overcome this issue.

### **vandalism**

As school grounds are often accessible after hours, the risk of vandalism is an issue that needs to be considered. See page 52.

### **emergency access**

Shade structures and/or planting should not restrict emergency vehicle access to school buildings and grounds.

### **existing services**

The location of shade structures and planting should take account of existing services, eg drainage, power lines, gas, water.

### **events**

Shade is an important consideration for sports and swimming days and other school events, eg fetes. Demountable structures may be useful on these occasions.

### **an additional resource**

The New South Wales Department of Education and Training publication *Sun shade in schools* is a useful additional resource. Full reference details can be found under *further reading* at the end of this section. See page 101.

---

## note

The Cancer Society of New Zealand's information sheet *Tree Planting for Schools* is a useful extra resource

---

## recommendations and considerations

The recommendations below are minimum shade guidelines for schools across New Zealand during summer. It is acknowledged that it may not be possible in the short term to implement all these recommendations due to funding constraints. However, medium-term plans should include improvements to summer shade provision as a priority.

Specific recommendations for winter shade have not been made due to differences in the prevailing climatic conditions across New Zealand during winter. However, the UV index is rarely more than one or two and risk levels are low in winter.

For some outdoor areas within a school, the need for winter shade is more pronounced. Where this is the case, the phrase 'shade throughout the year' is used in the following text.

---

### active playground

Partial shade is recommended for open playground areas, especially over grass which needs some sun for growth. Natural shade is the most appropriate option.

Consider arranging planting in clusters so that groups of children can access shade. Deciduous trees will allow for penetration of warmth and light to the playground during winter.

Shade throughout the summer is recommended over play equipment and sandpits. Consider using a combination of built and natural shade. The need for winter warmth and light are issues.

---

### passive playground

Shade during October to March is recommended for areas of passive playground use, eg fixed seating assembly areas.

Moveable seats should be placed in the shade.

Consider using a combination of natural and built shade.

The need for winter warmth and light should be considered.

---

## Schools

---

<b>covered outdoor learning areas (COLAs)</b>	<p>COLAs provide additional teaching space as well as wet weather space.</p> <p>When planning a COLA for an existing school, consideration should be given to constructing one of similar size to the standard core provision, ie between 150m<sup>2</sup> for 14 classes and 210m<sup>2</sup> for 21 classes.<sup>1</sup></p> <p>An additional area of 18m<sup>2</sup> or 24m<sup>2</sup> respectively can be included if incorporating the canteen covered area.<sup>2</sup></p> <p>For more detailed information on COLAs refer to the document <i>Sun Shade in Schools</i> listed under <i>further reading</i> at the end of this section.</p>
<b>canteen areas</b>	<p>Shade throughout the summer months is recommended for queuing areas.</p> <p>Built shade, eg a broad awning, is the most appropriate option.</p> <p>Rain protection is recommended.</p>
<b>pedestrian links</b>	<p>Shade is recommended for thoroughfares linking buildings and facilities within a school.</p> <p>Consider using a combination of natural and built shade.</p> <p>Rain protection is recommended, particularly where students are moving from one building to another throughout the day.</p>
<b>school bus stops</b>	<p>Shade is recommended for waiting areas at school bus stops, particularly during summer. Consider using natural shade, although where possible built structures that offer both UVR and rain protection should be provided.</p> <p>Although school bus stops will usually be part of the general streetscape and therefore outside the school boundaries, it may be possible to shade the area by planting trees immediately within the boundary.</p> <p>Local councils and transport authorities could be lobbied to provide built shelters.</p>

---

<sup>1</sup> New South Wales Department of Education and Training. *Sun shade in schools*. Sydney, 1998; 6.

<sup>2</sup> New South Wales Department of Education and Training, *Sun shade in schools*. Sydney, 1998.

---

<b>sports fields and facilities</b>	Refer to the section on <i>Sports grounds and facilities</i> in this chapter.
<b>swimming pools</b>	Refer to the section on <i>Public swimming pools</i> in this chapter.
<b>general</b>	Experience over a range of schools indicates that a typical amount of shade to ensure adequate protection would be 2.5m <sup>2</sup> per student. <sup>3</sup> However, the adequacy of shade protection cannot be measured by area alone. Shade quality, shade location and site usage patterns are also critical factors.

## further reading

- New South Wales Department of Education and Training. *Protection from the sun – Guidelines to assist in implementing the Student Welfare Policy*. Sydney, 1997.
- New South Wales Department of Education and Training. *Student Welfare: Protection from the sun Memorandum 97/152 (S.144)*. May 1997.
- Cancer Society of New Zealand. *Sample Sun Smart policies for primary/secondary schools*. Wellington, 2000.
- New South Wales Department of Education and Training. *Sun shade in schools*. Sydney, 1998.

---

<sup>3</sup> Greenwood J (Shade Consultant and Architect). Advice to New South Wales Cancer Council (unpublished). 1998.

## Swimming pools

# Swimming pools

---

Swimming is a popular activity in New Zealand during summer. For many people the public swimming pool offers a convenient and safe place for swimming. However, when pools are located outdoors, patrons' risk of excessive solar UVR exposure can be extreme. This is because:

- public pools are commonly used in summer when annual UVR levels are at their peak
- pool users typically wear minimal clothing
- there is often little shade
- there may be high levels of indirect UVR.

Thus the provision of sufficient UVR protective shade at these facilities is an issue that must be considered by pool owners and managers. Apart from contributing to the health and safety of their patrons, the increased comfort levels afforded by a well-designed shady environment are likely to increase customer satisfaction and even patronage.

It should be noted, however, that as shade can never provide total UVR protection, patrons should also be encouraged to adopt personal sun protection measures, ie wearing sun protective clothing, hats, sunscreen and sunglasses. Signage reminding pool users of these strategies, as well as the need to take particular care between 11am and 4pm, could be erected. Sun protection messages could also be broadcast over the public address system.

It should also be noted in regard to pool staff, eg lifeguards or swimming teachers, that the Health and Safety in Employment Act 1992 requires employers to identify and control the risk faced by workers required to work outdoors. Under the regulations, employees must cooperate with the measures that their employer puts in place to protect them.

---

### note

It is essential that an assessment of existing shade be made before the planning and design of additional shade commences.

Chapter 5 contains a step by step approach to conducting a Shade Audit, as well advice on managing a shade project.

an example of shade at a swimming pool

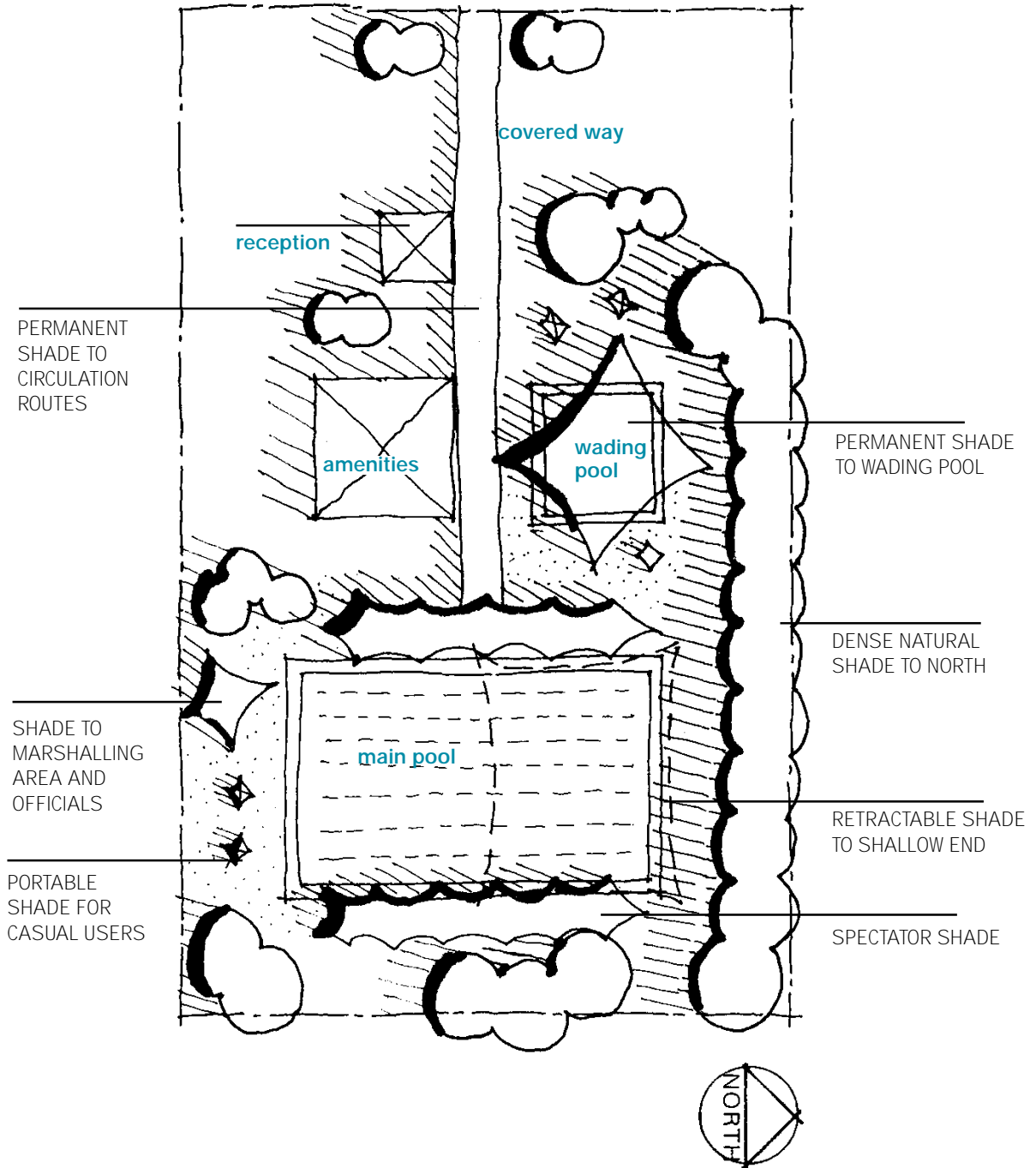

## Swimming pools

### planning and design issues

Many of the following considerations refer to concepts discussed in more detail in other parts of this publication. For this reason it is recommended that readers familiarise themselves with the content of Chapters 1 to 5 as well as Appendix C, before considering the specific issues for swimming pools.

#### existing shade

Plans should be made to optimise the use of existing shade before additional shade is considered, eg fixed seating could be relocated to a shaded area.

#### site usage patterns

It is important to take into account the usage patterns at the site, particularly the time/s of day and year it is most in use. Sufficient shade should be available at the times of heaviest usage, particularly when UVR levels are at their peak. To achieve this it may be necessary to supplement permanent shade with demountable structures.

Generally there are a number of areas of different use within a public swimming pool complex including:

- spectator areas
- aquatic areas
- concourse
- refreshment areas.

While each area has its own shade requirements, they should be considered within the context of the whole site.

#### carnivals

Providing shade is essential for major events such as carnivals and competitions. Demountable structures can be used to provide additional shade over spectator areas, as well as the areas for competitors and officials. Pool management could offer the use of such structures as part of pool hiring packages.

#### climatic conditions

It is important to take into account the overall characteristics of the particular climate zone in which the pool is situated, as well as any local conditions, eg strong wind. When these are understood it is possible to use design strategies to modify adverse conditions.

The effects of local conditions, particularly salt (in relation to corrosion) and wind, also need to be considered in the selection and design of shade structures as well as the selection of tree species.

#### indirect UVR

Indirect UVR is an important factor to consider due to the high levels of reflected UVR at public swimming pool complexes. While it is difficult to eliminate indirect UVR in this situation, exposure can be

minimised. For example, shade structures should be of a sufficient size to ensure people can move away from the edges. The shade canopy should extend at least one metre past the actual area of use and vertical barriers should be built into the sides.

The potential for exposure to indirect UVR should also be considered when selecting ground surfaces for the pool complex. Coarse and/or soft surfaces, eg brick pavers or grass, will reflect less UVR than hard and/or smooth surfaces, eg trowelled concrete. Existing surfaces can be modified if they reflect high levels of UVR.

#### aesthetics

Shade design should aim to be aesthetically pleasing as well as practical. An approach which combines both natural and built shade is preferable.

#### approval

Local councils will require development approval for built shade structures.

**natural shade**

Natural shade should be a significant element of shade provision for the perimeters of areas adjacent to pools. Trees with dense foliage and wide spreading canopies provide the best protection.

Species should be selected to suit local soil and climatic conditions as well as the character of the surrounding environment. Root barriers and subsoil drainage will help to ensure that pavements are not damaged by tree roots.

If natural shade is the long-term favoured option for areas within the pool complex, short-life built structures, ie with a lifespan of six to 10 years, can be used until trees planted for shade purposes mature.

**safety**

It is important to ensure that shade structures do not create safety hazards. Support systems, eg upright posts, should be clearly visible and ideally have rounded edges and/or padding. They should be placed so as to minimise intrusion into circulation areas. Where possible guy ropes should be avoided, as they may be a trip hazard.

**sightlines**

Shade structures should not obstruct lifeguards', spectators' or officials' views of the pool areas.

**corrosion**

The supporting systems of shade structures should not be placed in or near the pool as structural corrosion may occur.

**off-the-shelf structures**

In the appropriate situation, off-the-shelf structures can provide a readily available, cost-effective shade solution. However, unless a Shade Audit has been conducted, it is difficult to tell if they will meet the site's shade requirements. If the decision is made to purchase an off-the-shelf structure, the issues outlined in Chapter 4 of this publication should be considered.

**personal shade hire**

Personal shade structures such as umbrellas could be available for hire. The income from such a scheme could be used to provide additional shade at the site. However, it should be noted that because of indirect UVR umbrellas provide limited protection.

**existing services**

The location of shade structures and planting should take account of existing services, eg drainage, power lines, gas, water.

**an additional resource**

The Queensland Health publication *Shade for public pools* is a useful additional resource. Full reference details can be found under *further reading* at the end of this section. See page 107.

## Swimming pools

---

### recommendations and considerations

The recommendations below are minimum shade guidelines for public swimming pools across New Zealand during summer. It is acknowledged that it may not be possible in the short term to implement all these recommendations due to funding constraints. However, medium-term plans should include improvements to summer shade provision as a priority.

---

#### spectator areas

Shade is recommended over all seated spectator areas. Built shade is the most appropriate option. Rain protection is recommended.

Shade is recommended for general spectator areas, where people relax after a swim. A combination of natural and built shade is the most appropriate option. Sufficient shade should be available to allow most people to access shade. Demountable structures can be used to supplement permanent shade, particularly during summer.

---

#### aquatic areas

Shade is recommended over toddler pools and the surrounding supervising area. A permanent shade system is the most appropriate option.

Where possible, shade should be provided over the areas of the pool where most people spend their time and where children's swimming lessons are held. At most public pools, these are the shallow end and pool edges.<sup>1</sup> Consider using a demountable structure or an adjustable system, so that shade can be removed during winter.

Demountable shade is recommended for marshalling and official areas during carnivals and competitions.

---

<sup>1</sup> Minnery J. A report on B.B.C. swimming pools (unpublished report). Brisbane: Q Search, Queensland Institute of Technology (now Queensland University of Technology), 1988.

---

**concourse**

Consider extending shade canopies over pools or adjacent spectator areas so that the concourse is also shaded.

Where possible, ground surfaces should reflect minimal levels of UVR, heat and light.

---

**refreshment areas**

Shade is recommended for queuing areas at kiosks. Built shade, eg a broad awning, is the most appropriate option. Awnings should be of a sufficient size to cater for capacity crowds.

Shade is recommended over picnic tables and other areas where refreshments are consumed.

Where possible, ground surfaces should reflect minimal levels of UVR, heat and light.

**further reading**

- Alexander-Gabrielson M. *Swimming pools – A guide to their planning, design and operation*. Illinois: Human Kinetics Publishers Inc, 1987.
- Queensland Health and Department of Architecture, Queensland University. *Shade for public pools*. Brisbane, 1996.

## Beaches

# Beaches

---

Beach users' risk of excessive solar UVR exposure is extreme because:

- beaches are commonly used in summer when annual UVR levels are at their peak
- they typically wear minimal clothing
- they often spend extended periods of time at the beach
- there is little shade on the beach itself and there may not be sufficient shade at adjacent public reserves
- there are high levels of indirect UVR.

While the provision of sufficient UVR protective shade will contribute to a safer beach environment, it does not guarantee total protection from UVR. Beach users

should therefore be encouraged to adopt personal sun protection measures, ie wearing sun protective clothing, hats, sunscreen and sunglasses. Signage reminding people of these strategies, as well as the need to take particular care between 11am and 4pm during summer, could be erected.

It should also be noted in regard to beach staff, eg beach inspectors and lifeguards, that the Health and Safety in Employment Act 1992 requires employers to identify and control risks faced by workers required to work outdoors. An assessment should be made of the solar UV radiation to which workers are likely to be exposed and steps should be taken to try and minimise any risks. Workers should also take responsibility to look after their own health.

---

### note

It is essential that an assessment of existing shade be made before the planning and design of additional shade commences.

Chapter 5 contains a step by step approach to conducting a Shade Audit, as well advice on managing a shade project.

an example of shade at a beach

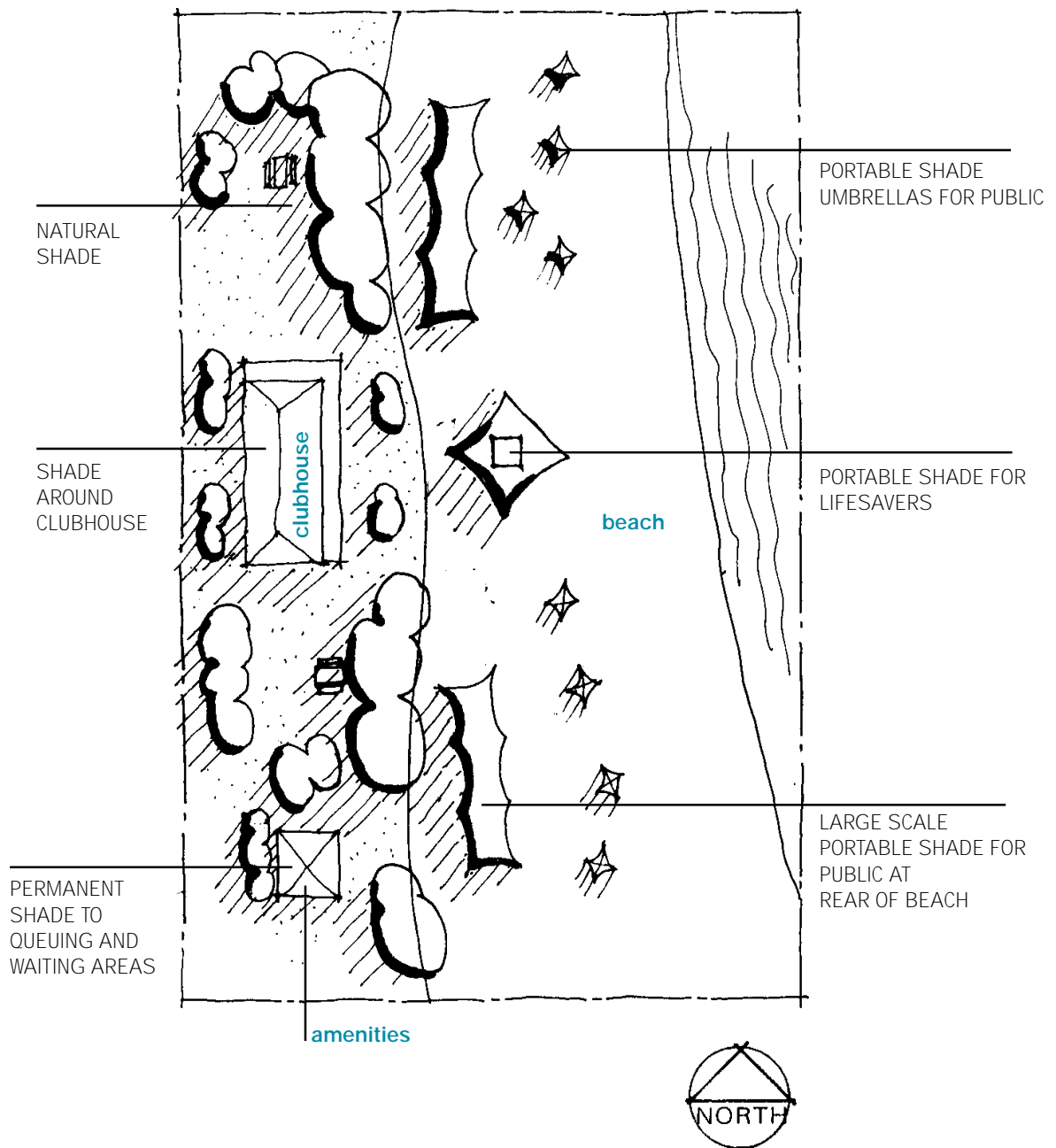

---

## planning and design issues

Many of the following considerations refer to concepts discussed in more detail in other parts of this publication. For this reason it is recommended that readers familiarise themselves with the content of Chapters 1 to 5 as well as Appendix C, before considering the specific issues for beaches.

### **sand areas**

Providing shade to the sand areas of beaches should be a major consideration. This can be achieved by cantilevering structures over the sand from walkways or areas immediately adjacent to the beach. Trees planted as near as possible to the sand may also provide shade. Lightweight structures, such as tension membrane structures or overhead sails, can be erected directly over the sand areas.

These could be designed to allow removal during winter months and could provide financial benefits by carrying sponsors' messages.

### **modifying site usage**

While it may not be feasible to provide permanent shade on the beach itself, permanent shade should be provided at adjacent public reserves. Beaches and adjacent reserves should be as integrated as possible so that people will be more inclined to retreat from unshaded sand areas. If reserves are slightly elevated, close to the sand, easily accessible and offer shade, they will be extensively used.

The shade requirements for different areas within a reserve will vary according to the type of activities that occur there. For example, in areas where people are sitting in one spot, eg picnic tables, the need for permanent shade over a significant part of the area is high. In areas where people are active and mobile, eg large grassed areas, it is more difficult to position shade so that it will be effective. Occasional scattered shade, however, should still be considered for these areas.

### **carnivals**

Shade is an important consideration for large scale events such as surf life saving carnivals. Demountable shade structures can be used to provide shade over spectator areas, as well as the areas for competitors and officials.

### **indirect UVR**

Indirect UVR is an important factor due to the high levels of reflected UVR at beaches. While it is difficult to eliminate indirect UVR in this situation, its effect on adjacent reserve areas can be reduced by planting panels of vegetation between the beach and reserve.

Shade structures at reserves, as well as on the sand, should also be designed to control indirect UVR. For example, they should be of a sufficient size to ensure people can move away from the edges. The shade canopy should extend at least one metre past the actual area of use, and vertical barriers should be built into the sides.

The potential for exposure to indirect UVR should also be considered when selecting ground surfaces within reserve areas. Coarse and/or soft surfaces, eg brick pavers or grass, will reflect less UVR than hard and/or smooth surfaces, eg trowelled concrete. Existing surfaces can be modified if they reflect high levels of UVR.

### **aesthetics**

Shade design should aim to be aesthetically pleasing as well as practical. Generally, an approach which combines built and natural shade is preferable.

**natural shade**

Natural shade should be a major element of shade provision at public reserve areas adjacent to beaches. Trees with dense foliage and wide spreading canopies provide the best protection.

Trees should be selected to suit local soil and climatic conditions as well as the character of the surrounding environment. They should also be salt-resistant. Root barriers and subsoil drainage will help to ensure that adjacent pavements are not damaged by tree roots.

If natural shade is the long-term favoured option for the reserve, short-life built structures, ie with a lifespan of six to 10 years, can be used until trees planted for shade purposes mature.

**safety**

It is important to ensure that shade structures do not create safety hazards. Support systems, eg upright posts, should be clearly visible and ideally have rounded edges. They should be placed so as to minimise intrusion into circulation areas. Where possible guy ropes should be avoided, as they may be a trip hazard.

**sightlines**

Shade structures should not obstruct peoples' views of the beach area, particularly lifeguards' views.

**corrosion and wind**

Shade structures in coastal areas will be subject to corrosion from salt as well as frequent high wind conditions. These issues should be considered in the design of supporting structures and the selection of shade materials.

**off-the-shelf structures**

In the appropriate situation, off-the-shelf structures can provide a readily available, cost-effective shade solution. However, unless a Shade Audit has been conducted, it is difficult to tell if they will meet the site's shade requirements. If the decision is made to purchase an off-the-shelf structure, the issues outlined in Chapter 4 of this publication should be considered.

**personal shade hire**

Personal shade structures such as umbrellas or sun domes could be available for hire. Surf clubs, neighbouring shops and/or local councils could provide this service. However, it should be noted that because of indirect UVR, umbrellas provide limited protection.

**vandalism**

As beaches and adjacent reserves are accessible at all hours of the day and night, the risk of vandalism is an issue that needs to be considered. See page 52.

## Beaches

---

### recommendations and considerations

The recommendations below are minimum shade guidelines for beaches and adjacent reserves across New Zealand during summer.

It is acknowledged that it may not be possible in the short term to implement all these recommendations due to funding constraints. However, medium-term plans should include improvements to summer shade provision as a priority.

---

#### sand areas

Consider providing shade to popular sand areas. Long-span lightweight demountable systems are the most appropriate option.

Trees and overhanging built structures located as close as possible to the edge of the beach will provide shade to sand areas, particularly during the afternoon.

Facilities for lifeguards should be fully shaded.

---

#### areas adjacent to beach

Shade should be provided at adjacent reserves, particularly towards the beach side. Refer to the section on *Parks and Reserves* in this chapter.

Shade is recommended for queuing areas at kiosks. Built shade, eg a broad awning, is the most appropriate option. Awnings should be of a sufficient size to cater for capacity crowds.

Shade is recommended over picnic tables and other areas where refreshments are consumed, particularly during the middle period of the day. Where possible, ground surfaces surrounding these areas should reflect minimal levels of UVR, heat and light.

---

## Sports grounds and facilities

# Sports grounds and facilities

---

Sports grounds and facilities are traditionally characterised by wide open spaces with little or no shade. As a result, people participating in or viewing activities at these venues often have little choice but to endure exposure to solar UVR for long periods of time. Thus the need for shade is generally high.

The provision of sufficient UVR protective shade at these facilities is therefore an issue that needs to be considered by owners and managers. Apart from contributing to the health and safety of spectators, officials and players, the increased comfort levels afforded by a well-designed shady environment are likely to encourage patronage.

It should be noted, however, that as shade can never provide total UVR protection, spectators and participants (where possible) should also be encouraged to adopt personal sun protection measures, ie wearing sun protective clothing, hats, sunscreen and sunglasses. Signage reminding people of these strategies, as well as the need to take particular care between 11am and 4pm during summer, could be erected. Sun protection messages could also be broadcast over the public address system.

It should also be noted in regard to employees, eg groundspeople or sports officials, that the Health and Safety in Employment Act 1992 requires employers to identify and control the risks faced by workers required to work outdoors. An assessment should be made of the solar UV radiation to which workers are likely to be exposed and steps should be taken to try and minimise any risks. Workers should also take responsibility to look after their own health.

---

### note

It is essential that an assessment of existing shade be made before the planning and design of additional shade commences.

Chapter 5 contains a step by step approach to conducting a Shade Audit, as well advice on managing a shade project.

an example of shade at a sporting field

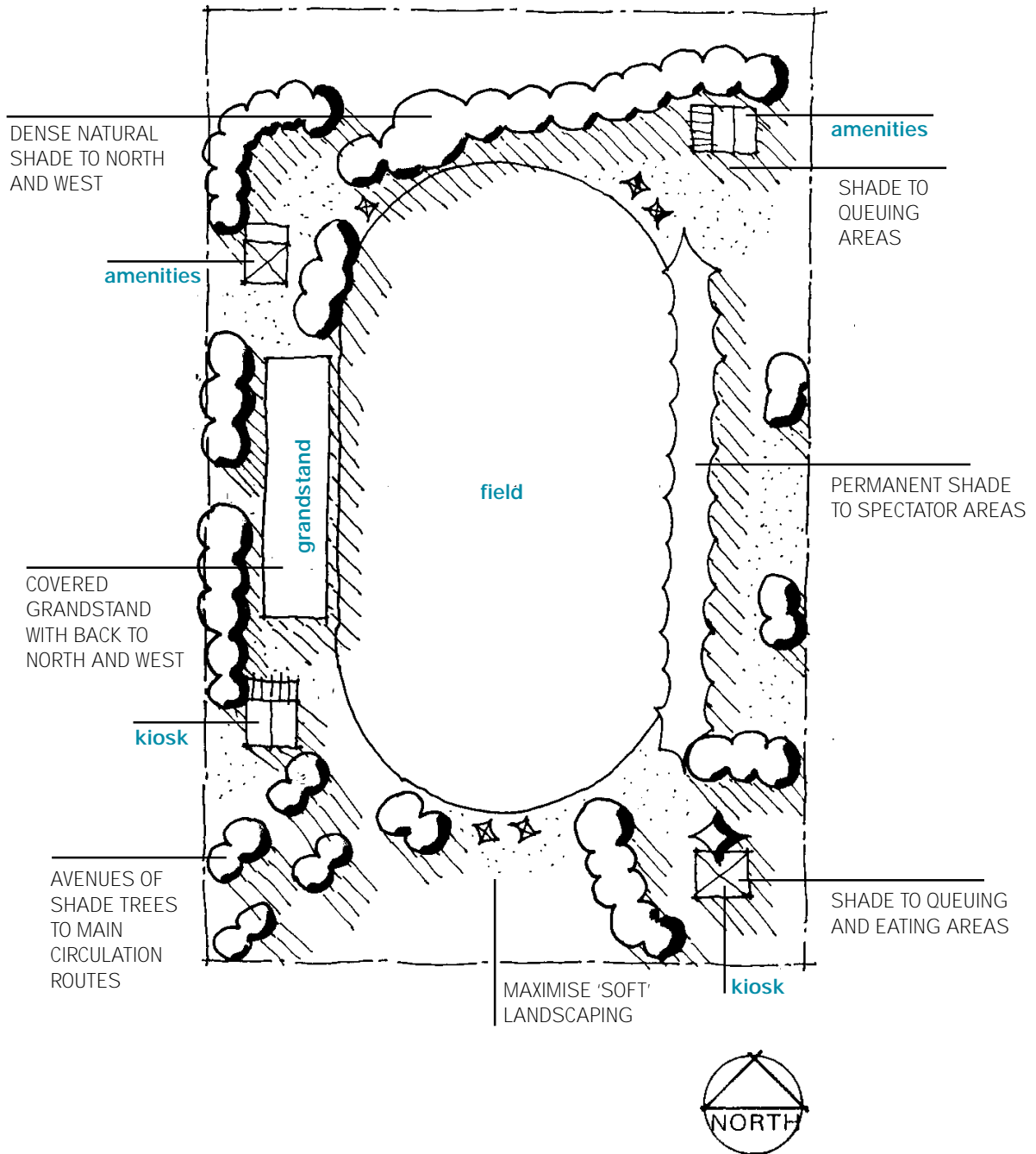

---

## planning and design issues

Many of the following considerations refer to concepts discussed in more detail in other parts of this publication. For this reason it is recommended that readers familiarise themselves with the content of Chapters 1 to 5 as well as Appendix C, before considering the specific issues for sports grounds and facilities.

### existing shade

Plans should be made to optimise the use of existing shade before additional shade is considered, eg fixed seating could be relocated to a shaded area.

### site usage patterns

It is important to take into account the usage patterns at the grounds/facility, particularly the time/s of day and year it is most in use. Sufficient shade should be available at the times of heaviest usage, particularly when UVR levels are at their peak.

For example, if games are usually played in the afternoon during summer, shade should be available at this time of day. To achieve this it may be necessary to supplement permanent shade with demountable structures.

Generally there are a number of areas of different use within a sports ground/facility including:

- spectator areas
- playing/competition areas
- refreshment areas
- entrance zones and pedestrian links.

While each area has its own shade requirements, they should be considered within the context of the whole site. Regardless of the scale of the facility, it is essential that shade is provided for players, officials and spectators.

### major events

Providing shade is very important for major events, eg cricket matches, where people are often at the sports ground/facility all day. Demountable structures can be used to provide additional shade over spectator areas, as well as the sideline areas for participants and officials. Site management could offer the use of such structures as part of ground/facility hiring packages.

### climatic conditions

It is important to take into account the overall characteristics of the particular climate zone in which the sports ground/facility is situated, as well as any local conditions, eg strong wind. When these are understood it is possible to use design strategies to modify adverse conditions.

The effects of local conditions, particularly salt (in relation to corrosion) and wind, also need to be considered in the selection and design of shade structures as well as the selection of tree species.

### seasonal considerations

Care needs to be taken to ensure that new shade initiatives do not intensify winter conditions at the site.

Summer shade provision should minimise UVR levels as well as reduce heat and light. Winter shade provision should allow for transmission of sufficient levels of heat and light.

### indirect UVR

Indirect UVR is an important factor to consider when designing built shade structures and selecting surfaces for the sports grounds/facilities. Coarse and/or soft surfaces, eg brick pavers or grass, will reflect less UVR than hard and/or smooth surfaces, eg trowelled concrete. Existing surfaces can be modified if they reflect high levels of UVR.

### aesthetics

Shade design should aim to be aesthetically pleasing as well as practical. Generally, an approach which combines both built and natural shade is preferable.

**approval**

Local councils will require development approval for built shade structures.

**natural shade**

Natural shade should be a major element of shade provision for areas within sports grounds/facilities. Trees with dense foliage and wide spreading canopies provide the best protection.

Species should be selected to suit local soil and climatic conditions as well as the character of the surrounding environment. Root barriers and subsoil drainage will help to ensure that pavements are not damaged by tree roots.

If natural shade is the long-term favoured option for areas within the grounds/facility, short-life built structures, ie with a lifespan of six to 10 years, can be used until trees planted for shade purposes mature.

**safety**

It is important to ensure that shade structures do not create safety hazards. Support systems, eg upright posts, should be clearly visible and ideally have rounded edges and/or padding. They should be placed so as to minimise intrusion into play and circulation areas. Where possible guy ropes should be avoided, as they may be a trip hazard.

**sightlines**

Shade structures should not obstruct spectators' or officials' views of the sports field/competition area.

**off-the-shelf structures**

In the appropriate situation, off-the-shelf structures can provide a readily available, cost-effective shade solution. However, unless a Shade Audit has been conducted, it is difficult to tell if they will meet the site's shade requirements. If the decision is made to purchase an off-the-shelf structure, the issues outlined in Chapter 4 of this publication should be considered.

**demountable structures**

Demountable shade structures should only be used to supplement more permanent forms of shade or when it is likely to be several seasons before a shade project can be completed. Some demountable structures, eg umbrellas, offer limited protection. Umbrellas also provide limited group space underneath and may be unstable during windy conditions.

**rain protection**

It may be desirable to provide both UVR and rain protection over areas for spectators, players and officials.

**vandalism**

As sporting grounds/facilities are often accessible at all hours of the day and night, the risk of vandalism is an issue that needs to be considered. See page 52.

**existing services**

The location of shade structures and planting should take account of existing structures, eg drainage, power lines, gas, water.

**an additional resource**

The Queensland Health publication *Shade for sports fields* is a useful additional resource. Full reference details can be found under *further reading* at the end of this section. See page 119.

## Sports grounds and facilities

---

### recommendations and considerations

The recommendations below are minimum shade guidelines for sports grounds and facilities across New Zealand during summer. It is acknowledged that it may not be possible in the short term to implement all these recommendations due to funding constraints. However, medium-term plans should include improvements to summer shade provision as a priority.

Specific recommendations for winter shade have not been made due to differences in the prevailing climatic conditions across New Zealand during winter. However, the UV index is rarely above one or two in winter and risk levels are low.

---

#### spectator areas

Shade is recommended over all seated spectator areas. Built shade is the most appropriate option. Rain protection is recommended.

Shade is recommended for general spectator areas, particularly the preferred viewing area/s, as this is where people will tend to congregate. A combination of natural and built shade is the most appropriate option. Sufficient shade should be available to allow at least 50 percent of the spectators to sit in the shade. Demountable structures can be used to supplement permanent shade.

Shade should be provided at different parts of the ground/facility as supporters of opposing teams usually prefer to congregate in distinct areas.

Shade should be provided close enough to the action. However, structures should not be located so as to create a hazard for players or to obscure views of the playing field/competition area.

---

#### playing fields/ competition areas

Players' off-field areas, eg baseball dugouts, should be shaded and if possible, protected from the rain. Warm-up areas should also be shaded.

The area/s where officials are located, eg scoring boxes and umpires' chairs, should be shaded and if possible protected from the rain. In some circumstances personal devices, eg an adjustable umbrella, may be the only viable option.

---

*playing fields/competition areas  
continued*

Where possible, the on-field areas should be shaded. For example, a tennis court could be covered with a large, clear span structure; each end of a bowling green could be covered with a retractable shade canopy.

The safety of players and officials is an important consideration. Ensure that there is suitable clearance between the edge of the playing field and the support system of the shade structure.

---

### refreshment areas

Shade is recommended for queuing areas at kiosks. Built shade, eg a broad awning, is the most appropriate option. Awnings should be of a sufficient size to cater for capacity crowds. Rain protection may also be a consideration when selecting awning materials.

Shade is recommended over picnic tables and BBQ areas, particularly during the middle period of the day.

Where possible, ground surfaces should reflect minimal levels of UVR, heat and light.

---

### entrance zones and pedestrian links

Consider planting avenues of trees to provide shade over pedestrian links between the entrance, main spectator areas and other activity zones.

Shaded seating could be provided at rendezvous points both inside and outside the grounds.

Where possible, ground surfaces should reflect minimal levels of UVR, heat and light.

### further reading

- Queensland Health and Department of Architecture, University of Queensland. *Shade for sports fields*. Brisbane, 1995.

## Parks and reserves

# Parks and reserves

---

Parks and reserves are used throughout the year by people of all ages, with heaviest usage often coinciding with the middle period of the day, when UVR levels are generally at their peak. Thus the need for shade at these venues is generally high.

It should also be noted in regard to employees, eg gardeners, that the Health and Safety in Employment Act 1992 requires employees to identify and control the risks by workers required to work outside. An assessment should be made of the risks to which workers are likely to be exposed and steps should be taken to identify and control any risks. Workers should also take responsibility to look after their own health.

It should be noted, however, that as shade can never provide total UVR protection, the public should also be encouraged to adopt personal sun protection measures, ie wearing sun protective clothing, hats, sunscreen and sunglasses. Signage reminding park users of these strategies, as well as the need to take particular care between 11am and 4pm during summer, could be erected.

---

### note

It is essential that an assessment of existing shade be made before the planning and design of additional shade commences.

Chapter 5 contains a step by step approach to conducting a Shade Audit, as well advice on managing a shade project.

an example of shade at a park

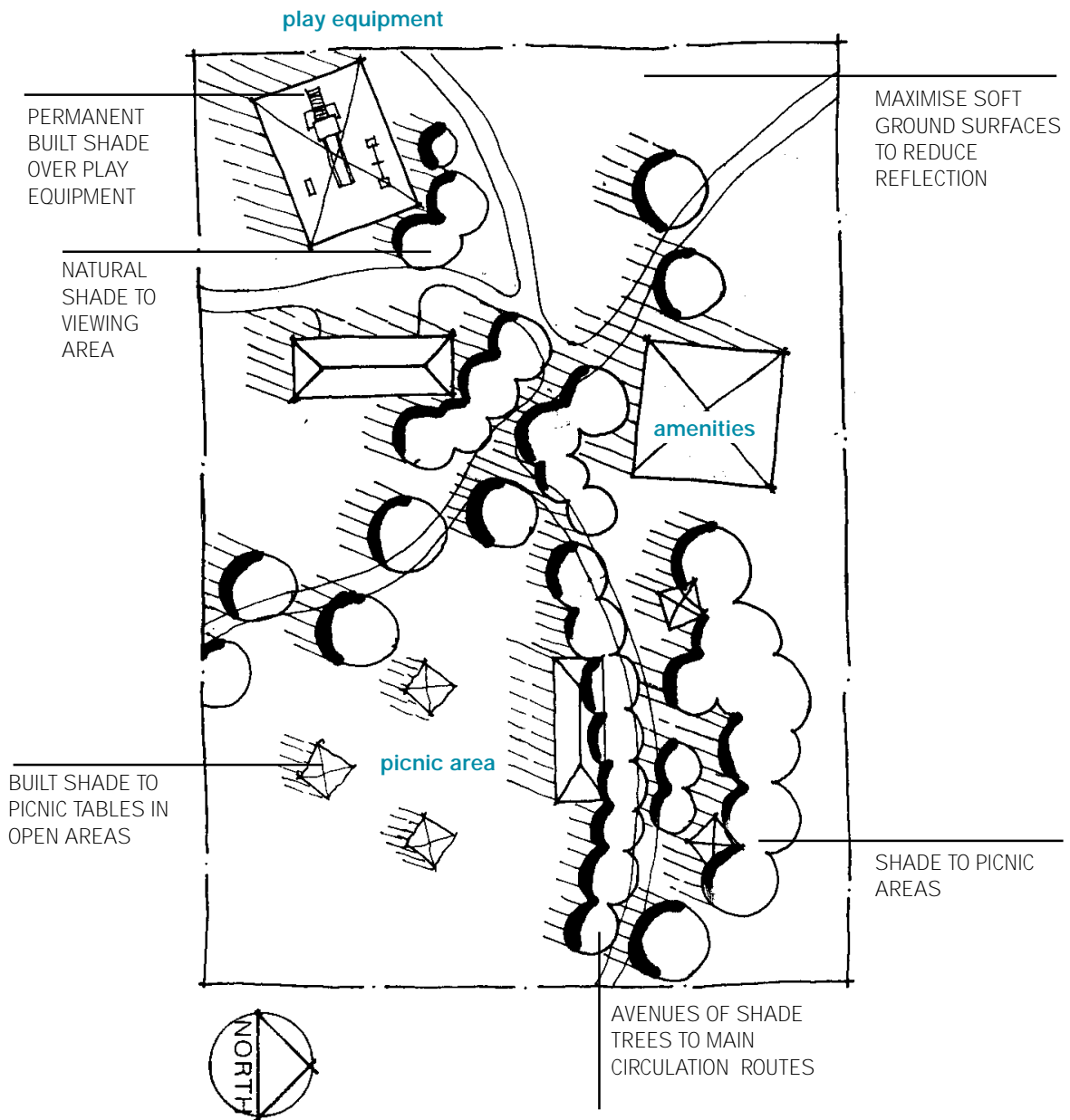

## planning and design issues

Many of the following considerations refer to concepts discussed in more detail in other parts of this publication. For this reason it is recommended that readers familiarise themselves with the content of Chapters 1 to 5 as well as Appendix C, before considering the specific issues for parks and reserves.

### existing shade

Plans should be made to optimise the use of existing shade before additional shade is considered, eg fixed seating could be relocated to a shaded area, low branches could be removed from trees to allow access.

### climatic conditions

It is important to take into account the overall characteristics of the particular climate zone in which the park/reserve is situated, as well as any local conditions, eg strong wind. When these are understood it is possible to use design strategies to modify adverse conditions.

The effects of local conditions, particularly salt (in relation to corrosion) and wind, also need to be considered in the selection and design of shade structures as well as the selection of tree species.

### site usage patterns

It is important to take into account the usage patterns at the site, including the type of activities that occur, where they occur and when they occur. Sufficient shade should be available at the times of heaviest usage, particularly when UVR levels are at their peak.

Generally there are a number of areas of different use within a park/reserve including:

- open areas
- playgrounds
- picnic and BBQ areas
- playing fields.

While each area has its own shade requirements, they should be considered within the context of the whole site.

### active vs passive use

The shade requirements for different areas within a park/reserve will vary according to the type of activities that occur there. For example, in areas where people are sitting in one spot, or where play is confined to a relatively small area, such as a playground, the need for permanent shade over a significant part of the area is high.

In areas where people are active and mobile, eg large grassed areas, it is more difficult to position shade so that it will be effective. Occasional scattered shade, however, should still be considered for these areas, so that park users have the opportunity to access shade.

### indirect UVR

Indirect UVR is an important factor to consider when designing built shade structures and selecting ground surfaces for areas within a park/reserve. Coarse and/or soft surfaces, eg brick pavers or grass, will reflect less UVR than hard and/or smooth surfaces, eg trowelled concrete. Existing surfaces can be modified if they reflect high levels of UVR.

### aesthetics

Shade design should aim to be aesthetically pleasing as well as practical. Generally, an approach which combines built and natural shade is preferable.

People commonly visit parks and reserves to enjoy the great outdoors. They will be less inclined to sit in the shade or even visit the park if structures are unattractive, poorly designed or unsympathetic to the surrounding environment.

### safety

It is important to ensure that shade structures do not create safety hazards. Support systems, eg upright posts, should be clearly visible and ideally have rounded edges and/or padding. They should be placed so as to minimise intrusion into circulation and children's play areas. Where possible guy ropes should be avoided, as they may be a trip hazard.

**approval**

Local councils will require development approval for built shade structures.

**natural shade**

Natural shade is a major element of shade provision at parks/reserves. Trees with dense foliage and wide spreading canopies provide the best protection.

Species should be selected to suit local soil and climatic conditions as well as the surrounding environment. Root barriers and subsoil drainage will help to ensure that pavements are not damaged by tree roots.

If natural shade is the long-term favoured option, short-life built structures, ie with a lifespan of six to 10 years, can be used until trees planted for shade purposes mature.

**off-the-shelf structures**

In the appropriate situation, off-the-shelf structures can provide a readily available, cost-effective shade solution. However, unless a Shade Audit has been conducted, it is difficult to tell if they will meet the site's shade requirements. If the decision is made to purchase an off-the-shelf structure, the issues outlined in Chapter 4 of this publication should be considered.

**rain protection**

It may be desirable to incorporate built structures that offer both UVR and rain protection into the design.

**vandalism**

As parks and reserves are often accessible at all hours of the day and night, the risk of vandalism is an issue that needs to be considered. See page 52.

**existing services**

The location of shade structures and planting should take account of existing services, eg drainage, power lines, gas, water.

**further reading**

For more information, see *further reading*, page 125.

## Parks and reserves

---

### recommendations and considerations

The recommendations below are minimum shade guidelines for parks and reserves across New Zealand during summer. It is acknowledged that it may not be possible in the short term to implement all these recommendations due to funding constraints. However, medium-term plans should include improvements to summer shade provision as a priority.

Specific recommendations for winter shade have not been made due to differences in the prevailing climatic conditions across New Zealand during winter. However, the UV index is rarely above one or two in winter and risk levels are low.

---

#### open areas

Partial shade is recommended for open areas, especially over grass which needs some sun for growth. Natural shade is the most appropriate option.

Consider arranging planting in clusters so that groups of people can access shade.

Fixed seating should be placed in the shade.

---

#### playground

Partial shade is recommended for open areas, especially over grass which needs some sun for growth. Natural shade is the most appropriate option.

Shade throughout the summer is recommended over children's play equipment. Generally, a permanent shade system is the most appropriate option. The need for winter warmth and light should be considered.

Seating should be placed in the shade and positioned to allow supervising adults a clear view of children at play.

---

---

**fixed play equipment**

Safety is a major consideration for shade provision over fixed play equipment.

Shade structures over fixed play equipment should not have footholds or grip surfaces which would allow for climbing.

The roofline of the shade structure should extend at least 500 millimetres beyond the edge of the deck of the play equipment, to prevent child access on to the roof.

The roof of the shade structure should allow for a minimum head clearance height of two metres above the deck of the play equipment.

Tree trunks and the upright posts of shade structures should be located a minimum distance of two metres away from the most fully extended part of the play equipment, eg the side of a climbing platform or the end of an extended swing arc. This will ensure sufficient freefall zones.

Any shade structure in the play area should be designed with reference to AS/NZS 4486.1:1997. See *further reading* below.

---

**picnic and BBQ areas**

Shade is recommended over picnic tables and BBQ areas, particularly during the middle period of the day when UVR levels are generally at their peak.

Where possible, ground surfaces should reflect minimal levels of UVR, heat and light.

Fire safety is an issue that needs to be considered in relation to BBQ areas, particularly when selecting materials for shade canopies and when planting trees.

---

**playing fields**

Refer to the section on *Sports grounds and facilities* in this chapter.

**further reading:**

- *AS/NZS 4422:1996 Playground surfacing – Specifications, requirements and test methods*. Standards Australia and Standards New Zealand.
  - *AS/NZS 4486.1:1997 Playgrounds and playground equipment Part 1 – Development, installation, inspection, maintenance and operation*. Standards Australia and Standards New Zealand.
-

## General streetscape

# General streetscape

---

The general streetscape includes footpaths and pedestrian thoroughfares, public transport points such as bus stops and taxi ranks and local shopping centres. These facilities are in daily use throughout the year.

The provision of sufficient UVR protective shade at these facilities is therefore vital in the development of a safe public environment. The increased comfort levels afforded by a well-designed shady environment are also likely to encourage patronage of local shopping facilities, as well as increase community satisfaction with these facilities.

It should be noted, however, that as shade can never provide total UVR protection, the public should also be encouraged to adopt personal sun protection measures, ie wearing sun protective clothing, hats, sunscreen and sunglasses. Signage reminding people of these strategies, as well as the need to take particular care between 11am and 4pm during summer, could be erected.

It should also be noted in regard to employees, eg street cleaners, that The Health and Safety in Employment Act 1992 requires employers to identify and control risks faced by workers required to work outdoors. An assessment should be made of the solar UV radiation to which workers are likely to be exposed and steps should be taken to try and minimise any risks. Workers should also take responsibility to look after their own health.

---

### note

It is essential that an assessment of existing shade be made before the planning and design of additional shade commences.

Chapter 5 contains a step by step approach to conducting a Shade Audit, as well advice on managing a shade project.

an example of shade on a general street

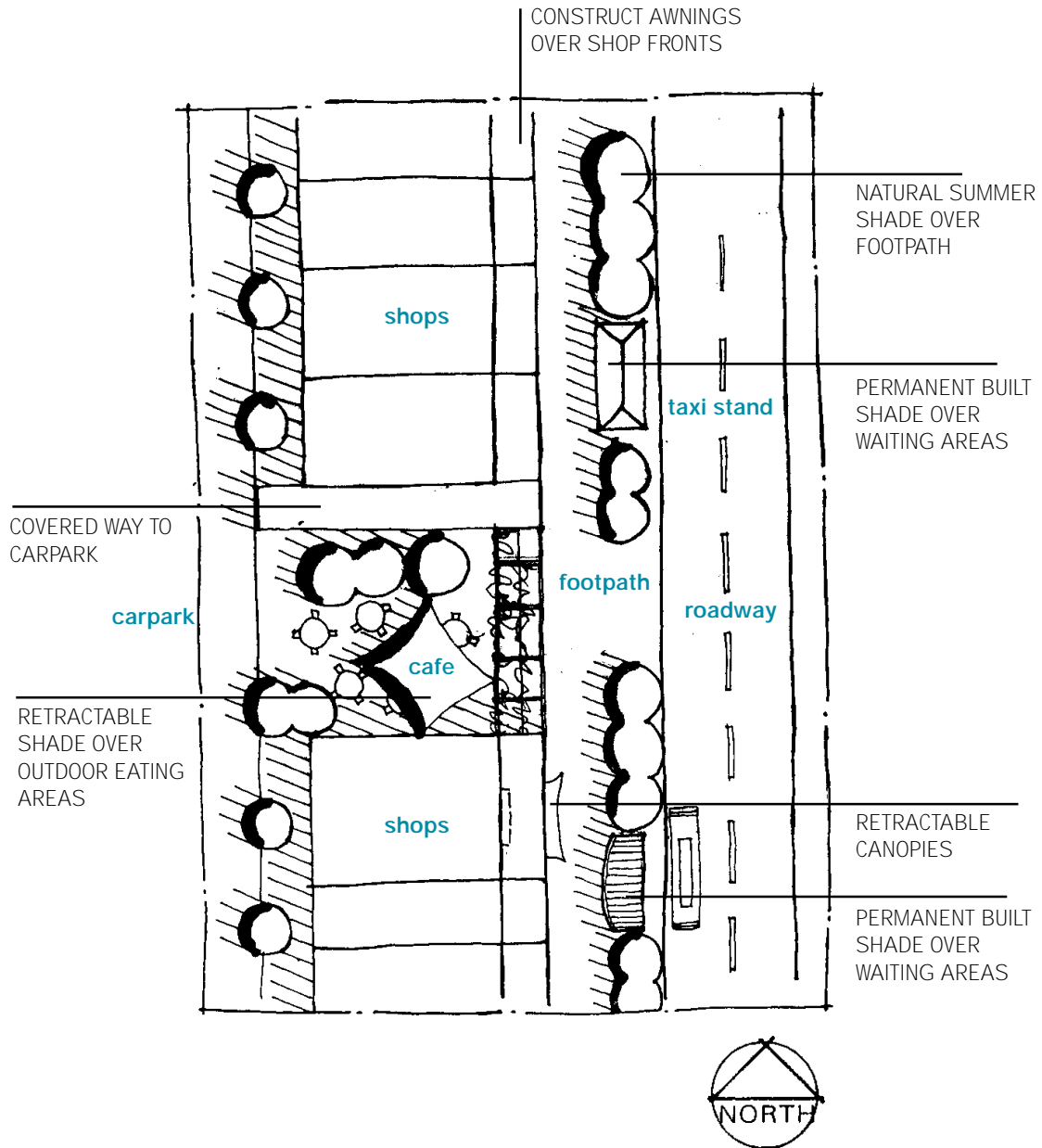

---

## planning and design issues

Many of the following considerations refer to concepts discussed in more detail in other parts of this publication. For this reason it is recommended that readers familiarise themselves with the content of Chapters 1 to 5 as well as Appendix C, before considering the specific issues for the general streetscape.

### existing shade

Plans should be made to optimise the use of existing shade before additional shade is considered, eg fixed seating could be relocated to a shaded area, low branches could be removed from trees to allow access.

### site usage patterns

It is important to take into account the usage patterns of streetscape areas, including the type of activities that occur, where they occur and when they occur. Sufficient shade should be available at the times of heaviest usage, particularly when UVR levels are at their peak.

### active vs passive use

Some locations within the classification 'streetscape' have usage patterns that involve prolonged exposure to UVR, eg areas where people congregate and linger in one spot, such as a courtyard in an outdoor shopping mall or waiting areas at bus stops and taxi ranks. The need for shade over a significant part of these areas is high and should be considered a priority.

In areas where people are active and moving, eg footpaths, it is more difficult to position shade so that it will be effective. Occasional scattered shade, however, should still be considered for these areas, so that people have the opportunity to access shade.

### climatic conditions

It is important to take into account the overall characteristics of the particular climate zone in which the streetscape areas are situated, as well as any local conditions, eg strong wind. When these are understood it is possible to use design strategies to modify adverse conditions.

The effects of local conditions, particularly salt (in relation to corrosion) and wind, also need to be considered in the selection and design of shade structures as well as the selection of tree species.

### seasonal considerations

Care needs to be taken to ensure that new shade initiatives do not intensify winter conditions at the site.

Summer shade provision should minimise UVR levels as well as reduce heat and light. Winter shade provision should allow for transmission of sufficient levels of heat and light. The use of adjustable shade systems and/or deciduous vegetation may provide greater flexibility.

### indirect UVR

Indirect UVR is an important factor to consider when designing built shade structures and selecting ground surfaces for streetscape areas. Coarse and/or soft surfaces, eg brick pavers or grass, will reflect less UVR than hard and/or smooth surfaces, eg trowelled concrete. Existing surfaces can be modified if they reflect high levels of UVR.

**aesthetics**

Shade design should aim to be aesthetically pleasing as well as practical. An approach that combines natural shade with well-designed, high quality shade structures will help to create aesthetically appealing streetscape areas (particularly local shopping centres) that will encourage patronage. One with unattractive, poorly designed structures that exclude natural shade may have the reverse effect.

**approval**

Local councils will require development approval for built shade structures.

**natural shade**

Natural shade should be a major element of shade provision for streetscape areas. Trees with dense foliage and wide spreading canopies provide the best protection. A 2.4 metre head clearance from the ground to the mature tree canopy is recommended.

Species should be selected to suit local soil and climatic conditions as well as the character of the surrounding environment. Root barriers and subsoil drainage will help to ensure that footpaths are not damaged by tree roots.

Councils should develop a street tree policy to ensure proper selection, planting and maintenance of street trees used for shade. The implementation of such policies will also help to improve the appearance of local streets.

If natural shade is the long-term favoured option for areas within the streetscape, eg a shopping mall, short-life built structures, ie with a lifespan of six to 10 years, can be used until trees planted for shade purposes mature.

**existing services**

The location of shade structures and planting should take account of existing services, eg drainage, power lines, gas, water.

**built shade safety**

It is important to ensure that shade structures do not create safety hazards. Support systems, eg upright posts, should be clearly visible and ideally have rounded edges and/or padding. They should be placed so as to minimise intrusion into play and circulation areas. Where possible guy ropes should be avoided, as they may be a trip hazard.

**off-the-shelf structures**

In the appropriate situation, off-the-shelf structures can provide a readily available, cost-effective shade solution. However, unless a Shade Audit has been conducted, it is difficult to tell if they will meet the site's shade requirements. If the decision is made to purchase an off-the-shelf structure, the issues outlined in Chapter 4 of this publication should be considered.

**rain protection**

It may be desirable to provide rain protection as well as UVR protection over some streetscape areas, eg bus stops.

**vandalism**

As streetscape areas are accessible at all hours of the day and night, the risk of vandalism is an issue that needs to be considered. See page 52.

## General streetscape

---

### recommendations and considerations

The recommendations below are minimum shade guidelines for general streetscape areas across New Zealand during summer. It is acknowledged that it may not be possible in the short term to implement all these recommendations due to funding constraints. However, medium-term plans should include improvements to summer shade provision as a priority.

Specific recommendations for winter shade have not been made due to differences in the prevailing climatic conditions across New Zealand during winter. However, the UV index is rarely above one or two during winter and risk levels are low.

---

#### footpaths

Shade is recommended for footpaths with significant levels of regular pedestrian traffic (at least one side of the street). Shade trees planted at regular intervals are the most appropriate option for residential areas.

Shade is recommended for pedestrian thoroughfares linking areas such as carparks to shopping centres and schools to transport points. Consider using shade trees, planted at regular intervals. Built shade may be appropriate in some locations.

---

#### public transport points

Shade throughout the year is recommended for waiting areas at major public transport points, eg at local shopping centres. As rain protection is also desirable, built shade is the most appropriate option. Trees could be planted to supplement the shade for capacity crowd situations.

Shade should also be provided at minor public transport points, eg in residential streets. Consider using natural shade, although where possible built structures that offer both UVR and rain protection should be provided.

---

---

### local shopping centres

General outdoor areas at local shopping centres require a mix of shade in summer and winter, as well as access to warmth and light in winter. Consider using natural shade as well as built shade for these areas.

Shade throughout the year is recommended over specified outdoor eating areas. Refer to the section on *Outdoor cafes, restaurants and beer gardens* in this chapter.

Shade is recommended over areas where people congregate and linger, eg seating areas in shopping mall courtyards.

Business operators should be encouraged to build awnings off their premises. As well as contributing to a shaded walkway for shoppers, these may help to increase patronage, as people will be more inclined to linger in cool, shaded areas outside shop windows.

Where possible, ground surfaces should reflect minimal levels of UVR, heat and light.

## Resorts, motels and hotels

# Resorts, motels and hotels

---

These facilities are characterised by a mix of specific use areas, eg swimming pools, beaches, outdoor sports facilities and outdoor restaurants/cafes as well as surrounding gardens and pathways. Guests will often spend significant amounts of time using these facilities, often during the middle period of the day when UVR levels are generally at their peak.

The provision of sufficient UVR protective shade at these facilities is an issue that must be considered by owners and managers. Apart from contributing to the health and safety of their guests, the increased comfort levels afforded by a well-designed shady environment are likely to increase customer satisfaction and even patronage.

It should be noted, however, that as shade can never provide total UVR protection, guests should also be encouraged to adopt personal sun protection measures, ie wearing sun protective clothing, hats, sunscreen and sunglasses. Signage reminding guests of these strategies, as well as the need to take particular care between 11am and 4pm during summer months, could be erected. Information could also be placed in the guests' rooms, and sunscreen could be included in the mini bar.

It should also be noted in regard to employees, eg pool attendants, tennis and golf professionals and gardeners, that The Health and Safety in Employment Act 1992 requires employers to identify and control the risks faced by workers required to work outdoors. An assessment should be made of the solar UV radiation to which workers are likely to be exposed and steps should be taken to try and minimise any risks. Workers should also take responsibility to look after their own health.

---

### note

It is essential that an assessment of existing shade be made before the planning and design of additional shade commences.

Chapter 5 contains a step by step approach to conducting a Shade Audit, as well advice on managing a shade project.

an example of shade at a resort

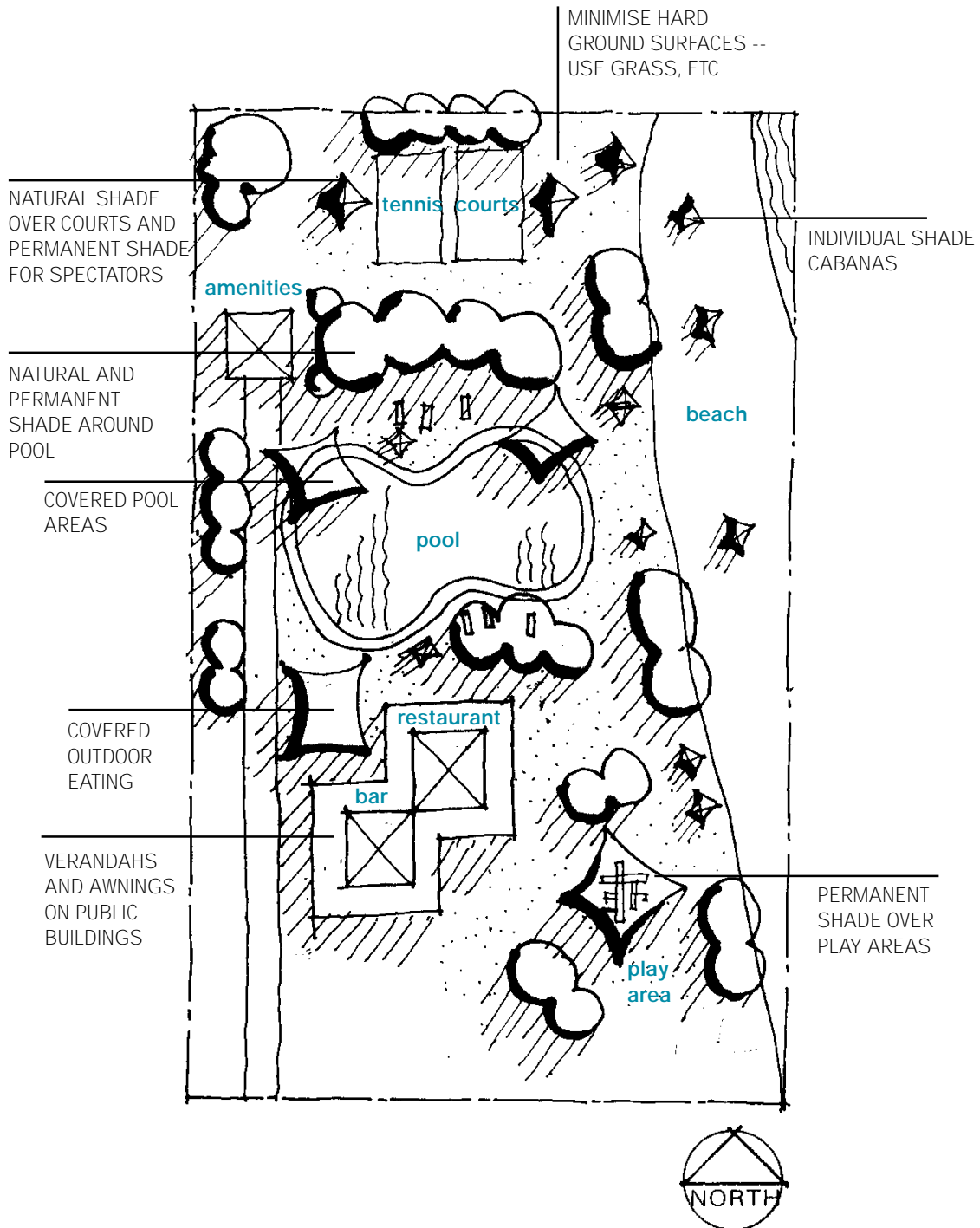

---

## planning and design issues

Many of the following considerations refer to concepts discussed in more detail in other parts of this publication. For this reason it is recommended that readers familiarise themselves with the content of Chapters 1 to 5 as well as Appendix C, before considering the specific issues for resorts.

### existing shade

Plans should be made to optimise the use of existing shade before additional shade is considered, eg fixed seating could be relocated to a shaded area, low branches could be removed from trees to allow access.

### site usage patterns

It is important to take into account the usage patterns at the site, including the type of activities that occur, where they occur and when they occur. Sufficient shade should be available at the times of heaviest usage, particularly when UVR levels are at their peak.

### active vs passive use

Within a resort, hotel or motel, the shade requirements for different areas will vary according to the type of activities that occur there. For example, in areas where people are sitting in one spot, eg outdoor eating areas, the need for permanent shade over a significant part of the area is high. In areas where people are active and mobile, eg large grassed areas, it is more difficult to position shade so that it will be effective.

Occasional scattered shade, however, should still be considered for these areas, so that guests have the opportunity to access shade.

### climatic conditions

It is important to take into account the overall characteristics of the particular climate zone in which the resort is situated, as well as any local conditions, eg strong wind. When these are understood it is possible to use design strategies to modify adverse conditions.

The effects of local conditions, particularly salt (in relation to corrosion) and wind, also need to be considered in the selection and design of shade structures as well as the selection of tree species.

### seasonal considerations

Care needs to be taken to ensure that new shade initiatives do not intensify winter conditions at the site.

Summer shade provision should minimise UVR levels as well as reduce heat and light. Winter shade provision should allow for transmission of sufficient levels of heat and light. The use of adjustable shade systems and/or deciduous vegetation may provide greater flexibility.

### indirect UVR

Indirect UVR is an important factor to consider when designing built shade structures and selecting ground surfaces for outdoor resort areas. Coarse and/or soft surfaces, eg brick pavers or grass, will reflect less UVR than hard and/or smooth surfaces, eg trowelled concrete. Existing surfaces can be modified if they reflect high levels of UVR.

**aesthetics**

Shade design should aim to be aesthetically pleasing as well as practical. An approach that combines natural shade with well-designed, high quality shade structures will help to create an aesthetically appealing environment that will increase customer satisfaction and encourage patronage. One with unattractive, poorly designed structures or which excludes natural shade may have the reverse effect.

**approval**

Local councils will require development approval for built shade structures.

**natural shade**

Natural shade should be a major element of shade provision for outdoor areas within a resort. Trees with dense foliage and wide spreading canopies provide the best protection.

Species should be selected to suit local soil and climatic conditions as well as the character of the surrounding environment. They should also be salt-resistant if the resort is located on the coast. Root barriers and subsoil drainage will help to ensure that pavements are not damaged by tree roots.

If natural shade is the long-term favoured option for areas within a resort, short-life built structures, ie with a lifespan of six to 10 years, can be used until trees planted for shade purposes mature.

**safety**

It is important to ensure that shade structures do not create safety hazards. Support systems, eg upright posts, should be clearly visible and ideally have rounded edges and/or padding. They should be placed so as to minimise intrusion into circulation and children's play areas. Where possible guy ropes should be avoided, as they may be a trip hazard.

**off-the-shelf structures**

In the appropriate situation, off-the-shelf structures can provide a readily available, cost-effective shade solution. However, unless a Shade Audit has been conducted, it is difficult to tell if they will meet the site's shade requirements. If the decision is made to purchase an off-the-shelf structure, the issues outlined in Chapter 4 of this publication should be considered.

**demountable structures**

Demountable shade structures should only be used to supplement more permanent forms of shade. Some demountable shade structures, eg a single umbrella, offer limited protection. The placement of umbrellas in groups may be a more effective way of using these items for shade purposes.

**rain protection**

It may be advisable to provide rain protection as well as UVR protection over some outdoor areas within a resort or other tourist facility, eg restaurants/cafes.

**existing services**

The location of shade structures and planting should take account of existing services, eg drainage, power lines, gas, water.

---

## recommendations and considerations

The recommendations below are minimum shade guidelines for resorts across New Zealand during summer. It is acknowledged that it may not be possible in the short term to implement all these recommendations due to funding constraints. However, medium-term plans should include improvements to summer shade provision as a priority.

Specific recommendations for winter shade have not been made due to differences in the prevailing climatic conditions across New Zealand during winter. However, the UV index is rarely above one or two in winter and risk levels are low.

---

### swimming pools

Shade throughout the year is recommended over toddlers' pools and the surrounding supervising area. A permanent shade system is the most appropriate option.

Where possible, shade should be provided over the areas of the pool where people most frequently spend their time while in the water. Consider using a demountable structure or an adjustable system, so that shade can be removed during winter.

Shade is recommended for areas adjacent to the pool, where people relax after a swim. A combination of natural and built shade is the most appropriate option. Sufficient shade should be available to allow most people to access shade. Demountable structures can be used to supplement permanent shade, particularly during summer.

Pool lounges and other seats should be placed in the shade, particularly during the middle period of the day.

Where possible, reduce the amount of smooth and/or hard surfaces around the pool by incorporating natural or synthetic grass.

---

### beaches

Refer to the section on *Beaches* in this chapter.

---

---

<b>outdoor dining areas</b>	Shade throughout summer is necessary over outdoor dining areas at resorts, hotels and motels. Refer to the section on <i>Outdoor restaurants, cafes and beer gardens</i> in this chapter.
<b>sports facilities</b>	<p>Shade is recommended for general spectator areas, particularly the preferred viewing area/s as this is where people will tend to congregate. Consider using a combination of natural and built shade.</p> <p>Where possible, on-court areas should be shaded, eg a tennis court could be covered with a large, clear span structure.</p> <p>Grass or synthetic grass are preferred ground surfaces as they reflect low levels of UVR.</p>
<b>picnic and BBQ areas</b>	<p>Shade is recommended over picnic tables and BBQ areas, particularly during the middle period of the day.</p> <p>Where possible, ground surfaces should reflect minimal levels of UVR, heat and light.</p> <p>Fire safety is an issue that needs to be considered in relation to BBQ areas, particularly when selecting materials for shade canopies and when planting trees.</p>
<b>pathways</b>	<p>Pathways should be designed to allow people to pass from one facility to another with minimum sun exposure. Consider planting avenues of trees to provide shade over pathways between facilities. Built shade may be appropriate in some locations.</p> <p>Shaded seating could be provided at rendezvous points within the resort's grounds.</p> <p>Where possible, ground surfaces should reflect minimal levels of UVR, heat and light.</p>
<b>playgrounds</b>	Refer to the section on <i>Parks and reserves</i> in this chapter.
<b>child care facilities</b>	Refer to the section on <i>Early childhood services</i> in this chapter.

---

## Outdoor restaurants, cafes and beer gardens

---

The mild climatic conditions experienced in New Zealand in summer have resulted in outdoor restaurants/cafes and beer gardens becoming increasingly common and popular. These venues are often at their busiest during lunchtime, when UVR levels are generally at their daily peak. Furthermore, food and drinks can often be consumed over a lengthy lunch, resulting in an increased risk of excessive solar UVR exposure for the patrons of these venues.

The provision of sufficient UVR protective shade at these venues is an issue that must be considered by owners and managers. Apart from contributing to the health and safety of their customers, the increased comfort levels afforded by a well-designed shady environment are likely to increase customer satisfaction and even patronage.

It should also be noted in regard to employees, eg waiters, that The Health and Safety in Employment Act 1992 requires employers to identify and control the risk faced by workers required to work outdoors. An assessment should be made of the solar UV radiation to which workers are likely to be exposed and steps should be taken to try and minimise any risks. Workers should also take responsibility to look after their own health.

---

### note

It is essential that an assessment of existing shade be made before the planning and design of additional shade commences.

Chapter 5 contains a step by step approach to conducting a Shade Audit, as well advice on managing a shade project.

## Outdoor restaurants, cafes and beer gardens

### an example of shade at an outdoor restaurant

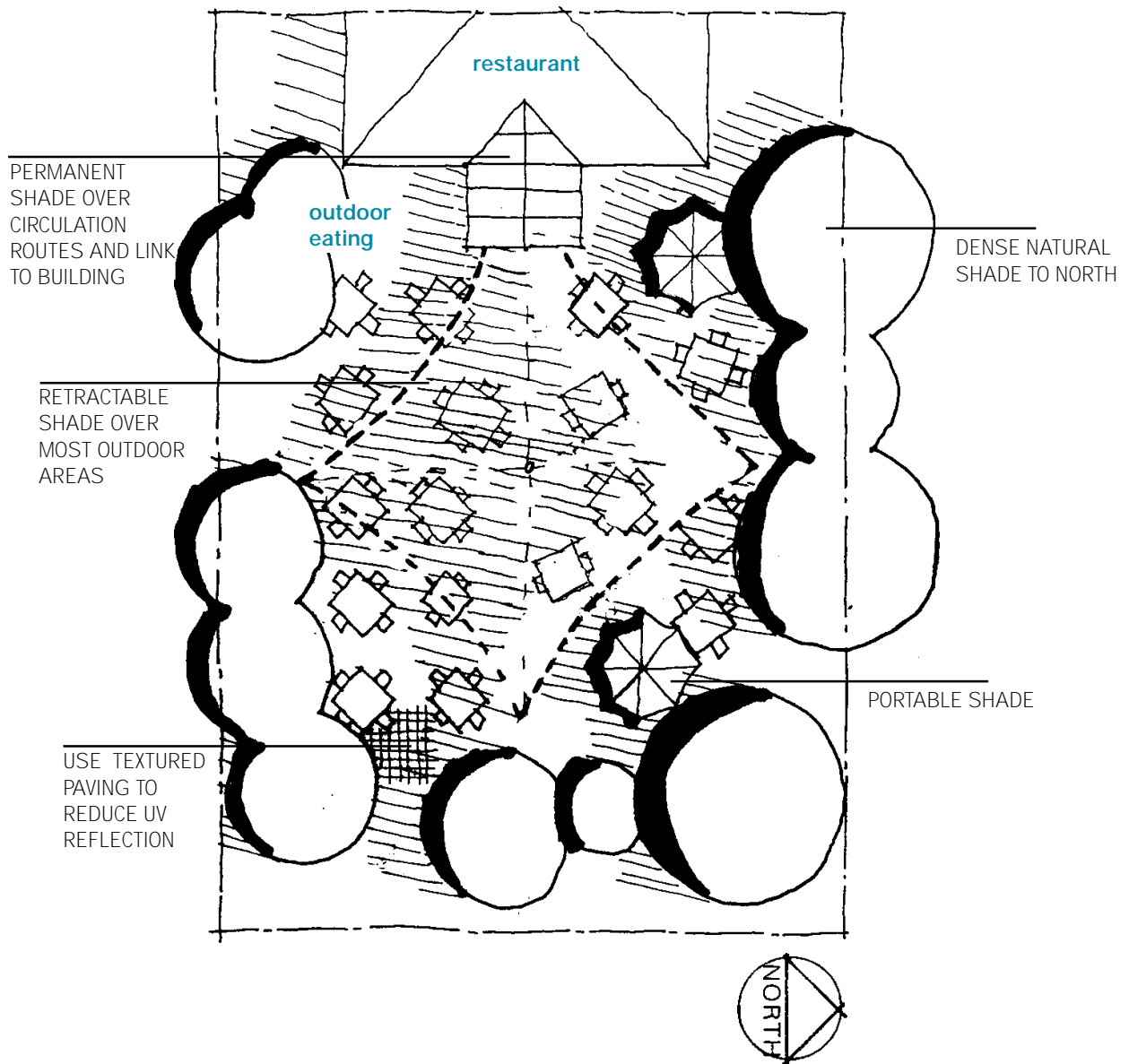

## Outdoor restaurants, cafes and beer gardens

### planning and design issues

Many of the following considerations refer to concepts discussed in more detail in other parts of this publication. For this reason it is recommended that readers familiarise themselves with the content of Chapters 1 to 5 as well as Appendix C, before considering the specific issues for outdoor restaurants, cafes and beer gardens.

#### climatic conditions

It is important to take into account the overall characteristics of the particular climate zone in which the outdoor restaurant/cafe or beer garden is situated, as well as any local conditions, eg strong wind. When these are understood it is possible to use design strategies to modify adverse conditions.

The effects of local conditions, particularly salt (in relation to corrosion) and wind, also need to be considered in the selection and design of shade structures as well as the selection of tree species.

#### seasonal considerations

Care needs to be taken to ensure that new shade initiatives do not intensify winter conditions at the site.

Summer shade provision should minimise UVR levels as well as reduce heat and light. Winter shade provision should allow for transmission of sufficient levels of heat and light. The use of adjustable shade systems and/or deciduous vegetation may provide greater flexibility.

#### indirect UVR

Indirect UVR is an important factor to consider when designing built shade structures and selecting ground surfaces for outdoor restaurants/cafes and beer gardens. Coarse and/or soft surfaces, eg brick pavers or grass, will reflect less UVR than hard and/or smooth surfaces, eg trowelled concrete. Existing surfaces can be modified if they reflect high levels of UVR.

#### aesthetics

Shade design should aim to be aesthetically pleasing as well as practical. An approach which combines natural shade with well-designed, high quality structures will help to create an aesthetically appealing venue that will encourage patronage. One with unattractive, poorly designed structures may have the reverse effect.

#### natural shade

Trees with dense foliage and wide spreading canopies provide the best protection. Species should be selected to suit local soil and climatic conditions as well as the character of the surrounding environment. Root barriers and subsoil drainage will help to ensure that pavements are not damaged by tree roots.

If natural shade is the long-term favoured option, short-life built structures, ie with a lifespan of six to 10 years, can be used until trees planted for shade purposes mature.

#### safety

It is important to ensure that shade structures do not create safety hazards. Support systems, eg upright posts, should be clearly visible and ideally have rounded edges and/or padding. They should be placed so as to minimise intrusion into circulation areas. Where possible guy ropes should be avoided, as they may be a trip hazard.

#### demountable structures

Demountable shade structures should only be used to supplement more permanent forms of shade. Some demountable shade structures, eg a single umbrella, offer limited protection. The placement of umbrellas in groups may be a more effective way of using these items for shade purposes.

#### off-the-shelf structures

In the appropriate situation, off-the-shelf structures can provide a readily available, cost-effective shade solution. However, unless a Shade Audit has been conducted, it is difficult to tell if they will meet the site's shade requirements. If the decision is made to purchase an off-the-shelf structure, the issues outlined in Chapter 4 should be considered.

#### rain protection

Built systems that offer rain protection as well as UVR protection will ensure that the outdoor areas can be used during wet weather.

#### existing services

The location of shade structures and planting should take account of existing services, eg drainage, power lines, gas and water.

---

## recommendations and considerations

The recommendations below are minimum guidelines for outdoor areas at restaurants/cafes and hotels. It is acknowledged that it may not be possible in the short term to implement all these recommendations due to funding constraints. However, medium-term plans should include improvements to summer shade provision as a priority.

Specific recommendations for winter shade have not been made due to differences in the prevailing climatic conditions across New Zealand during winter. However, the UV index is rarely above one or two in winter and risk levels are low.

---

Shade during summer is necessary over outdoor areas at restaurants, cafes and hotels.

During summer, it is recommended that at the absolute minimum, 50 percent of customers should be able to choose to sit in the shade. Similarly in winter, customers should be able to sit in the shade if they wish.

Consider using a combination of natural and built shade, eg a trellis covered with a climbing vine, as it will enhance the visual appeal of the space.

An adjustable built system and/or deciduous vegetation may be preferential, as it will allow for heat and light penetration during the cooler months.

Built systems that offer rain protection should also be considered.

It may be necessary to supplement permanent shade with demountable structures, particularly during summer.

Where possible, smooth and/or hard ground surfaces should be avoided. Coarse surfaces, eg brick pavers, will reflect less UVR.

---

## The home

# The home

---

Many homes have outdoor areas such as backyards, courtyards, decks, swimming pools, play areas and sandpits. The mild climatic conditions experienced in New Zealand encourage the regular use of these areas, often on a year-round basis.

The provision of sufficient UVR protective shade for outdoor areas within the home will contribute to the health and safety of family members (particularly children) and visitors. Well-designed shade will also enhance the aesthetic qualities of the home environment, resulting in outdoor spaces that are both visually appealing and comfortable to use.

It should be noted, however, that shade will not provide total UVR protection. The use of personal protection measures, ie sun protective clothing, hats, sunscreen and sunglasses is recommended. Care should also be taken to stay out of the sun between 11am and 4pm during summer, when daily UVR levels are generally at their peak.

---

### note

It is essential that an assessment of existing shade be made before the planning and design of additional shade commences.

Chapter 5 contains a step by step approach to conducting a Shade Audit, as well advice on managing a shade project.

an example of shade at home

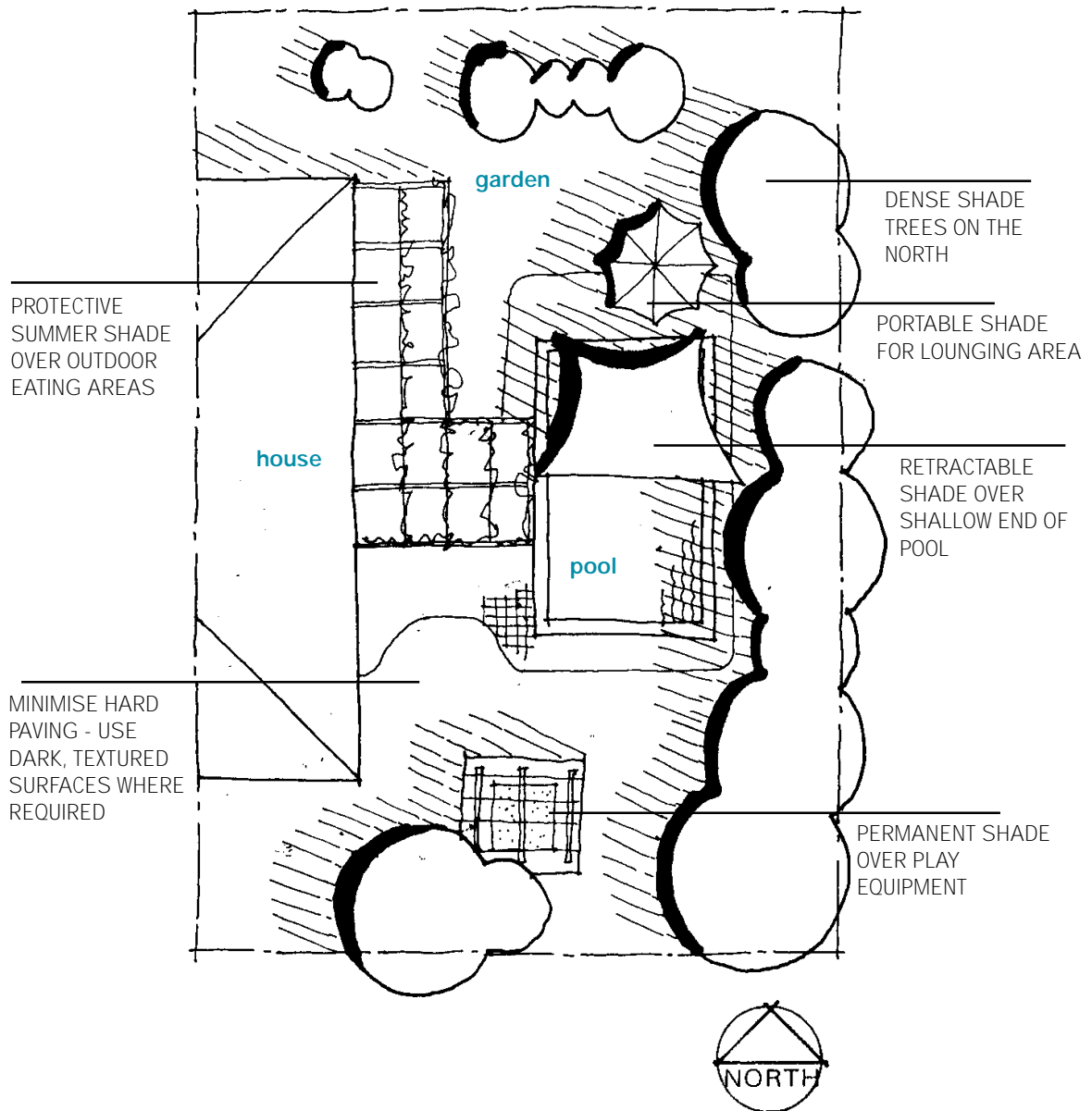

---

## planning and design issues

Many of the following considerations refer to concepts discussed in more detail in other parts of this publication. For this reason it is recommended that readers familiarise themselves with the content of Chapters 1 to 5 as well as Appendix C, before considering the specific issues for the home environment.

### existing shade

Plans should be made to optimise the use of existing shade before additional shade is considered, eg outdoor seating or play equipment could be relocated to a shaded area, low branches could be removed from trees to allow access.

### climatic conditions

It is important to take into account the overall characteristics of the particular climate zone in which the home is situated, as well as any local conditions, eg strong wind. When these are understood it is possible to use design strategies to modify adverse conditions.

The effects of local conditions, particularly salt (in relation to corrosion) and wind, also need to be considered in the selection and design of shade structures as well as the selection of tree species.

### seasonal considerations

Care needs to be taken to ensure that new shade initiatives do not intensify winter conditions at the site.

Summer shade provision should minimise UVR levels as well as reduce heat and light. Winter shade provision should allow for transmission of sufficient levels of heat and light. The use of adjustable shade systems and/or deciduous vegetation may provide greater flexibility.

### indirect UVR

Indirect UVR is an important factor to consider when designing built shade structures and selecting ground surfaces for outdoor areas within the home. Coarse and/or soft surfaces, eg brick pavers or grass, will reflect less UVR than hard and/or smooth surfaces, eg trowelled concrete. Existing surfaces can be modified if they reflect high levels of UVR.

### aesthetics

Shade design should aim to be aesthetically pleasing as well as practical. Generally, an approach which combines both built and natural shade is preferable.

### approval

Local councils will require development approval for built shade structures.

### natural shade

Natural shade should be a major element of shade provision for outdoor areas around the home. Trees with dense foliage and wide spreading canopies provide the best protection.

Species should be selected to suit local soil and climatic conditions as well as the character of the surrounding environment. Root barriers and subsoil drainage will help to ensure that pavements are not damaged by tree roots.

If natural shade is the long-term favoured option for outdoor areas around the home, short-life built structures, ie with a lifespan of six to 10 years, can be used until trees planted for shade purposes mature.

**built shade safety**

It is important to ensure that shade structures do not create safety hazards. Support systems, eg upright posts, should be clearly visible and ideally have rounded edges. They should be placed so as to minimise intrusion into circulation areas and children's play areas. Where possible guy ropes should be avoided, as they may be a trip hazard.

**off-the-shelf structures**

In the appropriate situation, off-the-shelf structures can provide a readily available, cost-effective shade solution. However, unless a Shade Audit has been conducted, it is difficult to tell if they will meet the site's shade requirements. If the decision is made to purchase an off-the-shelf structure, the issues outlined in Chapter 4 of this publication should be considered.

**demountable structures**

Demountable shade structures should only be used to supplement more permanent forms of shade. It should be noted that some demountable shade structures, eg a single umbrella, offer limited protection because of indirect UVR.

**rain protection**

It may be desirable to provide rain protection as well as UVR protection over some outdoor areas around the home, eg decks.

**existing services**

The location of shade structures and planting should take account of existing services, eg drainage, power lines, gas, water.

**thermal control**

If properly designed, external components of a house, eg verandahs, awnings, extended eaves, can provide considerable shade outdoors, as well as additional thermal control for inside areas of the house.

## The home

---

### recommendations and considerations

The recommendations below are minimum shade guidelines for homes across New Zealand during summer. It is acknowledged that it may not be possible in the short term to implement all these recommendations. However, medium-term home improvement plans should include summer shade provision as a priority.

Specific recommendations for winter shade have not been made due to differences in the prevailing climatic conditions across New Zealand during winter. However, the UV index is rarely above one or two during winter and risk levels are low.

---

#### general outdoor areas

Partial shade is recommended for general outdoor areas, especially over grass which needs some sun for growth. Natural shade is the most appropriate option.

If sufficient shade is available at all times of the day, it will allow greater flexibility for children's play.

Planting on the northern, northeastern and northwestern aspects of the site is recommended.

---

#### outdoor eating areas, decks and patios

Shade is recommended over outdoor eating and similar areas, eg decks and patios. Consider using a combination of natural and built shade, eg a trellis covered with a climbing vine, as it will enhance the visual appeal of the space.

An adjustable built system and/or deciduous vegetation will allow for heat and light penetration during the cooler months.

---

#### sandpits and play equipment

Shade throughout the summer months is recommended over sandpits, although built shade may be the most appropriate option. Pull-down screens at the side of the structure will help protect against indirect UVR.

Partial shade is recommended for the area which contains fixed play equipment. Natural shade is the most appropriate option.

The ability to supervise children is an important issue. Inappropriately located trees and shrubs and shade structures with solid and/or opaque sides may obstruct views of children playing.

---

---

**pool areas**

Shade throughout the summer is recommended over the relaxation area adjacent to the pool. Consider using built shade, as tree leaves may create ongoing pool maintenance problems.

Pool lounges and other seats should be placed in the shade, particularly during the middle period of the day.

---

**verandahs**

Verandahs will provide permanent shade as well as rain protection.

The angle of the roof and the extent of overhang should be designed to maximise shade for the major part of the day, especially during summer.

The width of the verandah should allow sufficient space for activities such as outdoor eating or children's play to occur.

Vertical pull-down blinds at the side of a verandah can provide additional protection from UVR when the sun is low in the sky.

**further reading**

- Ballinger JA, Prasad DK, Rudder D. *Energy efficient Australian housing*. Canberra: Australian Government Printing Service, 1992.
  - Commonwealth Department of Housing and Regional Development. *AMCORD – A national resource document for residential development*. Canberra: Australian Government Printing Service, 1995.
  - New South Wales Department of Urban Affairs and Planning. *NSW model code – A model for performance-based multi-unit housing codes*. Sydney, 1997.
-

## The workplace

# The workplace

---

Exposure to solar UVR represents a significant occupational hazard for people who work outdoors. The Health and Safety in Employment Act 1992 requires employers to identify and control the risk faced by workers required to work outdoors. An assessment should be made of the solar UV radiation to which workers are likely to be exposed and steps should be taken to try and minimise any risks. Workers should also take responsibility to look after their own health.

## general issues

The intensity of exposure to solar UV radiation will vary within and between occupational groups so OSH recommends a consultative approach to determine how far the responsibilities of the employer extend. In *Guidance notes for the protection of workers from solar ultraviolet radiation*, OSH states that it is not reasonable to suggest that particular actions (the provision of shade, protective clothing, sunscreen, or monitoring) be mandatory for all employers of outdoor workers. In some situations the employer's obligations may not extend beyond hazard (exposure) assessment and the provision of information to employees.

## considerations

The order in which the various means for limiting exposure to solar UV radiation are set out in the guidelines (job organisation, shade and personal protection) reflects the hierarchy required by the Health and Safety in Employment Act.

---

## note

It is essential that an assessment of existing shade be made before the planning and design of additional shade commences.

Chapter 5 contains a step by step approach to conducting a Shade Audit, as well advice on managing a shade project.

---

## recommendations and considerations

---

### exposure assessments

For each group of employees, an assessment should be made of the solar UV radiation to which they are likely to be exposed. This should include identification of the tasks with the time of day they are carried out and the period involved. The greatest risk occurs during 11am and 4pm during summer.

Other factors that may influence exposure to UV radiation should also be identified. These may include the shade provided by the working environment, reflective surfaces such as water, snow or bright building surfaces or any photosensitising substances associated with the work.

---

### minimising exposure

Employers should ensure the risk posed by exposure to solar radiation is minimised. In some instances this may be achieved by taking actions such as simply changing the time of day when a task is carried out. This is the preferred option, but where this is not practical, protection should be provided.

Where a job involves the use of large-scale, mechanical equipment, protective shade could be provided, for example:

- tractors, cranes, road-making equipment and the like should be fitted with transparent anti-glare UVR protective material surrounding the cabins
- trucks should be fitted with shade annexes to provide shaded work and rest areas
- boats should be fitted with shade canopies and awnings.

---

### job organisation

If a job involves both indoor and outdoor work, the potential for excessive solar exposure may be reduced by working indoors between 11 am and 4 pm during summer months.

---

## The workplace

---

---

### shade

Wherever possible, use should be made of natural shade, such as that provided by buildings and trees. If there is no natural shade available, then it may be feasible to erect temporary shade in the form of a canopy or screen. Structures can range from an adjustable umbrella, to a simple awning, through to a demountable structure. Some structures may offer commercial benefits by permitting work to continue during wet weather.

Glass is also partly effective in reducing the level of UV radiation. However, it is still possible to get sun-damaged skin while behind glass and additional personal protection may be needed.

Adequate shade should be provided over outdoor/lunch/teabreak areas and meeting places, especially at times when UVR levels are high, ie during the middle part of the day.

---

### personal protection

Personal protection is an important component in any plan to control exposure to solar radiation. An effective plan will usually involve protective clothing, hat and a sunscreen.

---

### training and education

Training should be provided when an exposure assessment has identified a need for action to minimise workers exposure to solar UV radiation. Training should be ongoing and focused on those responsible for organising outdoor work, new employees and those who are receiving prolonged exposure to solar UV radiation. Training should cover:

- awareness of the effects of solar UV radiation
- promotion of ways of minimise the risk
- the availability of information on the early detection of skin cancer by self checking.

### further reading

- OSH. *Guidance notes for the protection of workers from solar ultraviolet radiation*. Occupational Safety and Health Service New Zealand, Wellington, 1994.
  - OSH. *Learn the basic steps to make your workplace safer*. Occupational Safety and Health Service New Zealand, Wellington, 1999.
  - OSH. *What you need to know about temperature In places of work*. Occupational Safety and Health Service New Zealand, Wellington, 1997.
-

# Appendices



# Appendix A

## Responsibilities of public authorities\*

---

New Zealand and Australia have the highest rates of skin cancer in the world. Melanoma and other skin cancers, which are almost completely preventable, constitute a serious public health problem in New Zealand, for which public authorities should assume responsibility. The costs of not doing so are considerable. As well as the loss of life, pain and suffering caused by skin cancer, it is an expensive disease, costing the country around \$30 million a year in direct health expenditure.<sup>1</sup>

Public authorities in New Zealand lag behind their Australian counterparts in addressing this important health problem. In New South Wales, the Occupational Health and Safety Act 1983 obliges employers to protect the health and safety of employees. According to the WorkCover Authority of New South Wales, this means employees who work outside must be protected against the effects of excessive solar UVR exposure through a range of measures including the provision of shade.

There will inevitably be differing views as to the appropriate degree of intervention by the state, as opposed to the individual's freedom of action. However, as in the reform of public policy on smoking, which brought about the Smokefree Environments Act in 1990, it could be accepted that a serious public health problem demands an appropriate degree of intervention by Government (and therefore public authorities).

It is generally accepted there is a need to provide a safe environment for children. In this respect, greater initiatives should be taken to provide shade in schools, public parks, sports grounds and swimming pools, where children spend a large part of their time.

It is possible that public authorities may be found liable for not providing shade, and warnings about skin cancer. In addition to owing a general duty of care at common law, there may well be particular statutory duties that are incumbent on councils or other public authorities which could found liability. Breach of either of these could result in liability being visited on public authorities.

However, in the face of growing evidence about the risks of melanoma and skin cancer from exposure to UVR, public authorities should be anxious to take appropriate steps to prevent further damage, especially to children, by pursuing policies now for the provision of shade in outdoor spaces under their management and control.

\* Information supplied by KPMG Legal.

<sup>1</sup> Cancer Society of New Zealand. The costs of skin cancer to New Zealand. *Cancer Update in Practice*. Issue 2, 2000.



# Appendix B

## Professional and industry contacts

---

### **New Zealand Institute of Architects**

P.O. Box 2516  
Auckland  
ph (09) 623 6080

### **New Zealand Institute of Surveyors**

P.O. Box 831  
Wellington  
ph (04) 471 1774

### **New Zealand Institute of Landscape Architects**

P.O. Box 10-022  
Wellington  
ph 0800 843 694

### **Institute of Professional Engineers**

P.O. Box 12-241  
Wellington  
ph (04) 473 9444

### **Lightweight Structures Association of Australasia**

c/o Murray Higgs  
Structureflex NZ  
101 Central Park Drive  
Henderson  
Auckland  
Ph (09) 837 2350

### **Outdoor Fabric Products Association of New Zealand**

PO Box 22-124  
Christchurch  
New Zealand  
ph (03) 338 5243



# Appendix C

## Qualities of shade materials

---

	metal roof sheeting steel, aluminium, zinc, copper
suitability	Roofing and walling; steep or low pitches; curved and straight forms. Typically used for permanent fixed shade structures, although may be used as adjustable louvres. Most suited to summer shading where cool shade is required.
UVR protection	Excellent protection, UPF 50+.
waterproof	Yes.
light transmission	Opaque.
solar heat gain	Thermal resistance if insulated. Lighter colours reflect heat.
structural implications	Adequate 'tie-down' must be designed according to the wind code. Consult professional designer.
ease of replacement	Material readily available; easily re-fitted.
maintenance requirements	Subject to moisture or condensation conditions. Ensure all metallic particles are swept from roof on completion of installation to prevent staining and corrosion.
life span	Long life if well maintained. Fixings and flashing materials should have a lifetime similar to that of the roof covering material.
particular properties	Strongest of roofing and walling materials available. Long lengths and range of 'profiles' available. Can be cut to length. Some profiles can be curved.  Available in sandwich panels for increased insulation. Is often finished/coated to extend life span, eg galvanised, colourbond, stainless steel, or coated with plastics, eg PVC.
environmental considerations	Long-life spans mean less environmental impact in terms of material replacement. However, they need considerable support structure. Made from non-renewable resources. All high embodied energy although to differing degrees, aluminium is extremely energy intensive. All produce pollutants during manufacture (including coatings) but are generally contained. All are recyclable: steel and aluminium are commonly recycled and often contain recycled content. The potential of steel, copper and aluminium to be re-used is very good, especially if designed for disassembly. Steel and aluminium are good for collecting rainwater if properly sealed. The corrosion of copper and zinc may cause contamination of nearby water and soil.
relative cost	Economic for both small and large structures. Timber or steel frame required for support.

## Qualities of shade materials

### roof tiles concrete, clay, slate, fibre cement

suitability	Mainly roofing. Typically used for permanent fixed shade structures. Most suited to summer shading where cool shade is required.
UVR protection	Excellent protection, UPF 50+.
waterproof	Yes.
light transmission	Opaque.
solar heat gain	Better thermal performance if lined.
structural implications	Requires substantial support structure. Must be fixed to manufacturer's specification.
ease of replacement	Material readily available; easily fitted.
life span	Long. Fixings and flashing materials should have a lifetime similar to that of the roof covering material.
environmental considerations	All tiles have impacts during manufacture, are made of non-renewable resources, and require a comparatively large volume of material. Using locally reclaimed tiles lessens these impacts. Slate has the lowest manufacturing impacts. However, it is usually imported, which increases its embodied energy; reclaimed slate is preferable. Clay has high embodied energy, however this may be offset by long-life use, as it is more durable than concrete. Concrete tiles with slag instead of cement are preferable.
relative cost	Low, but support structure cost may be significant.

## Qualities of shade materials

	timber
suitability	Pergolas, trellis, lattice, screens, vertical or horizontal louvres. Suitable for use in combination with natural shade elements. Generally used in fixed permanent structures.
UVR protection	Solid sections provide excellent protection, UPF 50+. Other situations depend on density of construction, eg lattice or covering vegetation.
waterproof	Depends on detailing and use.
light transmission	Depends on detailing.
solar heat gain	Does conduct heat, but this is lessened in open air situations.
structural implications	Design for appropriate wind code.
ease of replacement	Usually readily available; ease of re-fitting depends on type of construction.
maintenance requirements	Guard against termites. If using preserved or treated timber care must be taken in handling. Painting or other protective treatment will extend life span.
life span	Longevity will depend on: ongoing maintenance and servicing; types of treatments; grade of timber used; type of timber, eg hardwoods/treated softwoods, as well as its detailing (how it is fixed).
particular properties	Available in a wide range of sizes and strengths. Can be also in sheet form, eg plywood.
environmental considerations	Timber is a renewable resource but only if forests are managed correctly. It generally has low embodied energy (depending on transport energy) but some wastage to produce building materials. The main issue with timber and environmental impact is its sourcing – preference should be given to sustainable managed forests or plantation resources. Timbers with the longest life span are hardwoods that are often unsustainably harvested. Look to use recycled/reclaimed timbers. Treatments that extend life span for timber are often highly toxic, especially copper chrome arsenic (CCA). As ammoniacal copper quaternary (ACQ) has less heavy metals than CCA, it is preferable; both treatments mean that timber cannot be burnt. Use of hardwoods can avoid this environmental problem. However, they are often from old growth forests. Life span can be extended beyond its initial use by keeping pieces in long lengths and designing for disassembly. For plywood sheeting, ensure facing is a sustainably grown local product and specify marine grade; other grades have higher volatile organic compounds in glues.
relative cost	Depends on design lengths, proposed usage, etc. Readily available, economical material.

## Qualities of shade materials

	<b>concrete</b>
	precast or in-situ, concrete blocks, autoclaved aerated concrete, fibre cement sheet
suitability	Walls, roofs, louvres, sunhoods. Suitable for permanent fixed structures.
UVR protection	Excellent protection, UPF 50+.
waterproof	Yes.
light transmission	Opaque.
solar heat gain	Absorbs heat slowly and re-transmits as air temperature falls.
structural implications	Requires substantial support and footings.
ease of replacement	Materials readily available; re-fitting depends on form of material – large pre-cast units and cast in-situ forms, eg suspended reinforced concrete slabs, very difficult to replace; smaller pre-manufactured units, eg fibre cement sunhoods or block walls, easily replaced.
maintenance requirements	Low.
life span	Long.
particular properties	Flexible material in many forms. Slow heat absorption.
environmental considerations	Uses a high volume of material with high embodied energy. Concrete (pre-cast, in situ or blocks) can be used as a thermal mass. All finite resources – scarcity is becoming an issue in some localities. Production of the critical ingredient (cement) is major contributor to CO <sub>2</sub> emissions (also nitrous oxides and sulphurous oxides emissions). Concrete aggregates may be supplemented with slag to reduce overall impact. Large volumes of water required in manufacture/ construction. Possibility for down-cycling.
relative cost	Low, but support structures cost may be significant.

## Qualities of shade materials

	<b>masonry</b>
	<b>clay bricks, rammed earth, mudbricks, straw bale</b>
suitability	Walls. Suitable for permanent fixed structures.
UVR protection	Excellent protection, UPF 50+.
waterproof	Yes.
light transmission	Opaque.
solar heat gain	Absorbs heat slowly and re-transmits as air temperature falls.
structural implications	Requires substantial support and footings.
ease of replacement	Materials readily available; re-fitting usually straightforward.
maintenance requirements	Low.
life span	Generally long; rammed earth and straw bales durable if protected by eaves.
particular properties	Slow heat absorption. Straw bales have far less thermal mass than others.
environmental considerations	Made from finite resources (although not scarce), these materials can also be used as an energy store (see Thermal mass in the Glossary). As walling, these materials use a high volume of material. Locally sourced natural stone, mudbricks, straw bale, and rammed earth have extremely low environmental impact. More traditional clay bricks have impacts in manufacturing of high embodied energy, contribution to acid rain, and the possible release of toxic gases. Re-used bricks or natural stone are therefore preferable and often available. Use soft mortar with clay bricks so that bricks can be re-used later.
relative cost	Low, though substantial footings required.

## Qualities of shade materials

### expanded metal mesh

suitability	Adjustable or fixed screens and wind deflectors. Openable roofs and walls.
UVR protection	Forms an effective shield depending on the position of the slit opening.
waterproof	No.
light transmission	Moderate transmission of light.
solar heat gain	Barrier to direct solar radiation while allowing ventilation.
structural implications	Can span quite large openings. Must withstand lateral forces. No uplift forces.
ease of replacement	Readily available.
maintenance requirements	Should be galvanised to ensure low maintenance.
life span	Very durable. Specify for appropriate life span, ie coatings and hole size to minimise rust.
particular properties	Depending on angle of mesh, will let air through.
environmental considerations	Non-renewable. However, it could contain a percentage of recycled content. No waste material in production as it is made from one continuous piece of metal. Requires less structural support than solid sheet metal and uses a low volume of material. Usually made from steel, also can be made from aluminium (which requires more energy to produce) and copper (which has some problems with nearby soil and water contamination). Different finishes usually applied pre-purchase: often galvanised, plastic coated, eg PVC, or painted. Can be recycled and re-used, especially if designed for disassembly.
relative cost	Low.

	perforated metal sheet
suitability	Screens, awnings and sunhoods. Use for both permanent and adjustable systems.
UVR protection	Varies as only solid sections provide barrier to UVR.
waterproof	No.
light transmission	Modulates light.
solar heat gain	Cuts direct solar radiation and allows ventilation.
structural implications	Must be strong enough to span required opening.
ease of replacement	Readily available; easily replaced.
maintenance requirements	Should be galvanised. Pre-painted sheets require low maintenance unless in a highly corrosive environment.
life span	Very durable. Specify for appropriate life span, ie coatings and hole size to minimise rust.
particular properties	Holes will allow air through.
environmental considerations	Non-renewable. However, it could contain a percentage of recycled content. Small amount of waste material in production. Requires less structural support than solid sheet metal and uses a low volume of material. Usually made from steel, also can be made from aluminium (which requires more energy to produce) and copper (which has some problems with nearby soil and water contamination). Different finishes usually applied pre-purchase: often galvanised, plastic coated, eg PVC or painted. Can be recycled and re-used, especially if designed for disassembly.
relative cost	Low.

## Qualities of shade materials

### glass

suitability	Roofs or walls. Use where light and/or visibility is required. Generally permanent fixed structures.
UVR protection	Depends on thickness and type. Ordinary window glass offers little protection from UVR. Laminated glass can absorb almost all UVB; by contrast, toughened glass transmits some UVB. Additives during manufacture and reflective surface laminates can affect UVR penetration.
waterproof	Yes.
light transmission	High depending on tint.
solar heat gain	Less heat gain if tinted.
structural implications	Talk to manufacturer to select glass appropriate to the job.
ease of replacement	Usually readily available and easily re-fitted.
maintenance requirements	Needs regular cleaning. Breakage and safety issues if not toughened or laminated.
life span	Long life if it doesn't sustain impact or over-pressurisation.
particular properties	Transparency allows wide range of uses, eg windbreaks.
environmental considerations	High embodied energy although small volume of material required. Additives and coatings required to provide UVR protection made of oxides of metals: iron, nickel, cobalt, silver halide which complicate the recycling of glass and may have disposal complications. Glass used in buildings is not currently recycled and has very little recycled component.
relative cost	Reasonably high compared to other translucent materials. May require more sophisticated support structure.

## Qualities of shade materials

	polycarbonate sheeting
suitability	Roofing, walling, louvre systems, awnings, skylights and canopies. Typically used for permanent fixed shade structures, although could be used as adjustable louvres. Most suited to winter shading where warm shade is required.
UVR protection	Very high protection.
waterproof	Yes.
light transmission	High. Differs according to thickness, profile and colour. Clear or opal transmits more light and heat than darker tints.
solar heat gain	High. Becomes warm and produces a heating effect.
structural implications	Design structure for wind uplift.
ease of replacement	Readily available; easily re-fitted.
maintenance requirements	Low maintenance. Impact resistant.
life span	About 10 years. Material may become brittle and discolouration may occur sooner than 10 years.
particular properties	Long lengths; range of profiles and colours available.
environmental considerations	<p>The environmental problems associated with plastics such as polycarbonate sheeting occur in their manufacture and disposal – they cause fewer problems during construction and use. Toxicity during manufacture depends on the stabilisers used (which is what protects polymer from solar degradation so is necessary for shade provision). These are often environmentally dangerous (especially phosgene).</p> <p>Solvents used in polymer manufacture are problematic – the most common, methylene chloride, is a suspected carcinogen. Made from non-renewable resources, high embodied energy offset by low amount of material needed. Can be recycled, but generally down-cycled. Because of long life span and durability, potential for re-use high; specify shapes/mouldings and support structures with this in mind. Will not decompose. Disposal is to landfill. Good for water collection. Requires less structural support materials.</p>
relative cost	Low.

## Qualities of shade materials

### fibreglass sheeting teflon coated, silicone coated

suitability	Roofing, walling, louvre systems, awnings, skylights and canopies. Typically used for permanent fixed shade structures, although could be used as adjustable louvres. Most suited to winter shading where warm shade is required.
UVR protection	Very high protection. Differing UV stabilisers and coatings will change level of UPF.
waterproof	Yes.
light transmission	High. Various tints, UV stabilisers and coatings will change level of light transmission. Clear or opal transmits more light and heat than darker tints.
solar heat gain	High. Becomes warm and produces a heating effect.
structural implications	Design structure for wind uplift.
ease of replacement	Readily available.
maintenance requirements	Low maintenance. Impact resistant.
life span	Coatings (such as teflon/silica) protect the resin/glass fibres from weathering and will extend the life span, as will detailing. Weathering will gradually make material more opaque.
particular properties	Fibreglass sheeting consists of glass fibres mixed with polymer resins. Can be bought in sheets or moulded for specific applications.
environmental considerations	Material uses non-renewable resources. High embodied energy as well as problems with toxicity and volatile organic compounds in manufacture, although manufacturers are increasingly following best practice initiatives. Pollution and waste during manufacture depends on type of plastic resin and stabilisers used. Currently not recycled in New Zealand; re-use dependent on design specification, ie whether bought in sheeting or hand-moulded.
relative cost	Low.

## Qualities of shade materials

	<b>canvas or similar tightly woven cloths</b>
suitability	Good for adjustable, short-term fixed and demountable structures. Not suitable for large projects.
UVR protection	Good protection when new. Prolonged or severe weathering may reduce UPF.
waterproof	Watertight up to saturation point. Greater protection can be achieved using coatings.
light transmission	Lighter colours transmit greater light.
solar heat gain	Darker colours gain more heat.
structural implications	Guy ropes cause obstruction.
ease of replacement	Readily available. Ease of replacement of individual panels usually means that the whole structure would need to be dismantled.
maintenance requirements	Lacks self cleaning properties. Is not mould resistant. Life span can be extended by regular maintenance and proper drying to inhibit rotting. Will still retain strength even if partially affected by rot.
life span	Limited. Susceptible to break down due to UVR exposure.
particular properties	Wide range of colours and fabric designs; also wide range of proprietary products available using canvas.
environmental considerations	Usually made from low grade (otherwise waste material) canvas, although can be made from hemp and flax. Renewable resource although high use of water, fertilisers and pesticides in production. Canvas (especially for outdoor application) usually finished with a waterproofing agent such as aluminium or plastic sprays such as polyurethane (which have high toxic volatile organic compound emissions) to extend life. Low volume of material in relation to area covered, and low volume of structural support material needed. At end of life will degrade but waterproof coatings may cause leaching problems in landfills.
relative cost	Material cost low, though some proprietary products may be relatively expensive on a square metre basis.

## Qualities of shade materials

### PVC coated polyester fabric

suitability	Canopies and side panels. Highly curved structures – not suitable for flat surfaces. Typically used for fixed permanent structures though can be retractable or demountable. Most popular material in use for construction of fabric structures.
UVR protection	Very good.
waterproof	Yes.
light transmission	High.
solar heat gain	Heat transmission is similar to glass.
structural implications	Structures must resist wind load, especially uplift.
ease of replacement	Fully imported material, though readily available. Ease of re-fitting depends on use; 'structural' fabrics may require dismantling of structure for full replacement. Can be readily patched.
maintenance requirements	High gloss self-cleaning surfaces.
life span	Minimum seven to eight years in zones experiencing intense UVR. Effective life is very dependent on location and environment; in excess of 20 years likely in areas of low pollution. Pollution acts as a corrosive agent on PVC surface causing erosion. Vehicle emissions are among the worst polluting agents. Manufacturers usually provide five year guarantee.
particular properties	Usually white or light cream in colour. Usually coated with clear Tedlar film which assists cleanability and prolongs the life of the PVC medium. Easy to work with. Fire resistant – fabric will char or holes will be formed if placed over a flame source but is not likely to ignite.
environmental considerations	PVC and polyester are from non-renewable resources. Problems in production due to stabilisers/additives such as fire retardants, which may also leach in landfills. High pollution and toxicity during manufacture of PVC (though closed systems can minimise escape of dioxins). Support structure needed is minimal and volume of material is small in relation to the area covered. After use, product can be re-used unless is too degraded. PVC can theoretically be 'downcycled' and polyester recycled, but combination of the two cannot be recycled. Both are thought to release dioxins in landfill.
relative cost	Relatively expensive.

## Qualities of shade materials

	teflon coated fibreglass fabric (PTFE)
suitability	Large span canopies – able to achieve lower curvatures than PVC coated polyester. Fixed permanent structures – not recommended for retractable systems or flat surfaces.
UVR protection	Very high.
waterproof	Yes.
light transmission	Translucent.
solar heat gain	Less heat gain if tinted.
structural implications	Structures must resist wind loads, especially uplift.
ease of replacement	Fully imported. Consider using smaller panels for ease of replacement in the case of damage and to ensure continuous use of the covered space.
maintenance requirements	Beware of potential for water ponding in sudden downpours.
life span	Very durable. Design life of 20 to 30 years.
particular properties	More difficult to fabricate and erect than PVC polyester. Non-combustible – satisfies building code requirements for fire protection in enclosed spaces, eg shopping malls. Resistant to UVR exposure and airborne pollution.
environmental considerations	Non-renewable resource. High embodied energy in production. Low volume of material needed in relation to area, and minimal support structures. Toxicity in production, though is generally contained. Cannot be incinerated or recycled, usually goes to landfill where there may be some problems with leaching.
relative cost	About two to three times the cost of PVC coated polyester fabric structures.

## Qualities of shade materials

### knitted polyethylene (shade cloth)

suitability	Proprietary products such as canopies and freestanding pavilions. Commonly used for shade in car yards.
UVR protection	<p>UPF varies according to colour, fabric density and degree of stretch. Only the solid sections form a barrier to UVR. Typically, cover factors vary from less than 50 percent UVR protection to more than 90 percent. Shade cloths with a rating of 90 percent give only medium UVR protection or UPF 10. Double knits or double layers may give a higher UPF.</p> <p>Use only fabric that provides 94 percent or greater protection from direct UVR.</p>
waterproof	Porous, lacks rain protection.
light transmission	Lighter colours allow more light but reflect and scatter more UVR.
solar heat gain	Darker colours are hotter but reflect less UVR.
structural implications	Minimal down or uplift force due to porous nature of the material.
ease of replacement	Readily available – many different sources and countries of origin. Re-fitting generally easy.
maintenance requirements	Keep clear of tree debris to avoid sagging problems. Susceptible to mould growth and dirt pick-up.
life span	About five years depending on location. It should be noted that shade cloth may be characterised by poor durability if used in a location that is subject to windy conditions. Prone to vandalism.
particular properties	Easier to fabricate than solid fabrics. High stretch fabric. Curved surfaces can be formed easily.
environmental considerations	Contains no chlorides. However, additives to ensure low flammability are often highly toxic and can emit volatile organic compounds. Short life span means regular replacement. Less structural material needed due to small weight. After use it is too degraded to be recycled and usually goes to landfill; it can be incinerated depending on additives. Easily transported. Not suitable for water collection/other uses.
relative cost	Inexpensive. Cost of different cloths is directly proportional to quality.

### woven PVC coated yarn (shade cloth)

suitability	Adjustable and fixed systems, outdoor furniture and other proprietary products.
UVR protection	<p>UPF varies according to colour, fabric density and degree of stretch. Only the solid sections form a barrier to UVR. Typically, cover factors vary from less than 50 percent UVR protection to more than 90 percent. Shade cloths with a rating of 90 percent give only medium UVR protection or UPF 10. Double knits or double layers may give a higher UPF.</p> <p>Use only fabric that provides 94 percent or greater protection from direct UVR.</p>
waterproof	Porous, lacks rain protection.
light transmission	Lighter colours allow more light but reflect and scatter more UVR.
solar heat gain	Darker colours are hotter but reflect less UVR.
structural implications	Minimal down or uplift force due to porous nature of the material.
ease of replacement	Readily available, many different sources and countries of origin. Re-fitting generally easy.
maintenance requirements	Keep clear of tree debris to avoid sagging problems. Susceptible to mould growth and dirt pick-up.
life span	About five years depending on location. It should be noted that shade cloth may be characterised by poor durability if used in a location that is subject to windy conditions. Prone to vandalism.
particular properties	Easier to fabricate than solid fabrics. High stretch fabric. Curved surfaces can be formed easily.
environmental considerations	PVC is made from non-renewable resources. The type of yarn used may either be renewable or non-renewable. High toxicity during manufacture of PVC (though closed systems can minimise escape of dioxins). Its short life span means regular replacement and thus more material. Volume of material is small in relation to the area covered. After use, this product is usually too degraded to be recycled. Not suitable for water collection/other uses.
relative cost	Inexpensive. Cost of different cloths is directly proportional to quality.

## Qualities of shade materials

	shingles and shakes timber, fibre-cement
suitability	Roofing and walling. Aesthetic suitability in some contexts. Fixed permanent structures.
UVR protection	Excellent protection, UPF50+.
waterproof	Yes.
light transmission	Opaque.
solar heat gain	Better thermal performance if lined.
structural implications	Structural framework required.
ease of replacement	Material may not be readily available; high degree of skill required.
maintenance requirements	High. Shingles may require fireproofing treatments.
life span	Long.
particular properties	Available in timber, usually western red cedar, or fibre-cement.
environmental considerations	Timber shingles may be derived from a renewable source (which depends upon timber source). They require little energy in manufacture, are biodegradable and able to be re-used. Fibre-cement products (both shingles and sheets) have relatively minimal environmental impact and are otherwise resource efficient. As they are durable they should be used in long-life applications as their potential for re-use and recycling is poor.
relative cost	Expensive, labour intensive to install.

## Qualities of shade materials

	thatch
suitability	Roofing, screens and windbreaks. Suitable for fixed permanent structures.
UVR protection	Excellent protection, UPF 50+.
waterproof	Yes.
light transmission	Opaque.
solar heat gain	Excellent thermal insulator, cool in summer.
structural implications	Structural framework required.
ease of replacement	Material may not be readily available, special skill required.
maintenance requirements	Relatively high.
life span	Greatly depends on the type of reed or grass used and the craftsmanship in construction. Life span of 50 years or more, which is comparable with metal sheet, fibre cement and concrete tiles.
particular properties	May attract insects and termites. Excellent insulating properties.
environmental considerations	Environmentally advantageous material as it is renewable and often a locally available resource. No manufacturing impacts and is extremely low in embodied energy (especially if sourced locally). As an organic material it is easily disposed of, and can act as a nutrient. Possible problems with flammability in dense urban areas.
relative cost	Reasonable. Material is inexpensive though labour component during fixing is intensive and costly.



## The Shade Inventory

---

### What is the Shade Inventory?

The Shade Inventory can be used to prioritise the need for protective shade. It is most useful for organisations that are responsible for a large number of outdoor locations. For example, councils have a large number of sites within their local government area for which they are directly responsible. A Shade Inventory will provide the framework for a strategic plan that will allow funds to be directed, in the first instance, to the sites of greatest need.

The Shade Inventory can also be a useful tool in situations where sites are so large that they become a collection of individual settings, each requiring its own shade assessment, eg universities and hospitals.

The Shade Inventory lists and prioritises settings in order of need, allowing the organisation to allocate funds and plan the provision of protective shade in an orderly and effective manner.

### Using the Shade Inventory

To prioritise a range of sites according to their need for protective shade, two factors must be considered and assessed:

- site usage patterns, which help to determine the extent to which users are likely to be exposed to harmful solar UVR (solar risk)
- the extent of existing shade.

### Assessing usage patterns

#### user group

The characteristics of the user group, particularly age, are important in determining the risk of UVR-related skin damage. Research indicates that children and adolescents exposed to large amounts of solar UVR have a significantly greater chance of developing skin cancer later in life. Accordingly, sites where children and adolescents are the main users would be a high priority for solar protective shade.

#### time of use

The period of greatest daily UVR intensity is usually between 11am and 4pm during the summer months. Sites with high usage between these times have an increased need for protective shade.

The period of greatest seasonal UVR intensity is summer. Therefore, sites used extensively in summer have greater priority shade needs than those used predominantly in winter.

#### duration of use

The length of time over which the outdoor activity takes place is an important factor. This is because the longer the period of exposure to solar UVR, the greater the risk of harm. It should be noted that in summer, sunburn can occur in as little as 12 minutes.

#### level of usage

Sites that enjoy high levels of usage would generally be expected to take priority over less utilised sites. However, usage patterns can change over time.

If usage level is a determining factor in deciding priority, periodic checks should be made to see if the usage levels have changed. Should the level of usage of a site change significantly, its priority grading should be reconsidered.

### likelihood of risk behaviour

In situations where outdoor activity is likely to occur in minimal clothing, such as beaches and swimming pools, the priority for shade would be high.

Also, children at play may be more likely to engage in risk behaviour than adults, who may seek out shade for protection or comfort. Even in situations where children may be under the supervision of an adult, it should not necessarily be assumed that their behaviour will be low risk, as the supervising adult may not be aware of the need for solar protection, or indeed enforce solar protection strategies.

## Assessing existing shade

A detailed assessment of the adequacy of existing shade would not be undertaken at the Shade Inventory stage. Rather, this would be done during the Shade Audit. However, two sites having a similar degree of solar risk can be prioritised by comparing the extent of existing shade. The site observed to have the least shade would be graded as having a higher need for shade.

See Chapter 5, *The Shade Project*, for a full discussion of the Shade Audit process.

## Example of a completed Shade Audit undertaken for a school

### Introduction

#### aims

The aims of this Shade Audit are to:

- assess the existing external environment of the school
- evaluate shade availability and needs
- identify achievable solar protection opportunities by provision of shade.

It is hoped that the Audit will become an integral component of an overall school solar protection policy. The policy would include the following elements:

- the provision of adequate shade
- scheduling of outdoor activities to minimise UVR exposure
- a sun-protective school uniform
- the use of sunscreen when appropriate
- a sun protection education/awareness programme for children and parents.

#### expected UVR levels

Sydney, at latitude 34° south, has high levels of UVR. (Auckland is at latitude 37° and has similar levels of UVR.) Summer levels are considerably higher than winter levels, due mainly to lower solar altitude angles in winter. Cloud cover can significantly affect solar UVR levels, with heavy cloud reducing UVB to less than five percent of the clear sky value.

On cloud free days, the maximum UVB level occurs at solar noon (1pm daylight saving time in Australia and 1.30pm in New Zealand). In summer, 50 percent of the total UVB received during the course of the day occurs within two hours either side of solar noon.

On a summer day with clear skies, a time of around 11 minutes in the sun will result in potentially damaging exposure to UVB. In winter, it will take longer to exceed recommended levels.

### Site description and use

The school is located on the corner of Harry and Milly Streets. The southern boundary adjoins Thea Avenue with the western boundary adjoining residential properties. A site plan is shown on page 178.

For the purposes of this study, the landscaped area on Harry Street, in front of the school, has been excluded, though this forms an important part of the external environment used by school children. As access to this area is restricted, its inclusion would give an inaccurate impression of the shaded area normally available to the children.

Classes are conducted in accordance with Department of School Education timetable, comprising four terms per year, of approximately 10 weeks duration per term. Holidays during the mid-summer period mean that the school is closed during late December and most of January, when the highest levels of solar radiation are encountered.

Typically, the playground is used as follows:

- prior to 9.25am free play
- 9.30am children form into class groups
- 11.15am morning break
- 1.20pm lunch, taken seated in playground
- 1.55pm free play.

In addition, classes undertake external sport and fitness activities, including dance, during the teaching period of the day.

The school caters for approximately 330 children, ranging in age from five to 12 years, and employs 15 staff.

### note

This sample Shade Audit was prepared for a Sydney primary school by a shade consultant. Although the issues to be addressed in Shade Audits will vary widely according to the location and use of the site, the general format and content of the sample provide a useful guide.

Sample audit

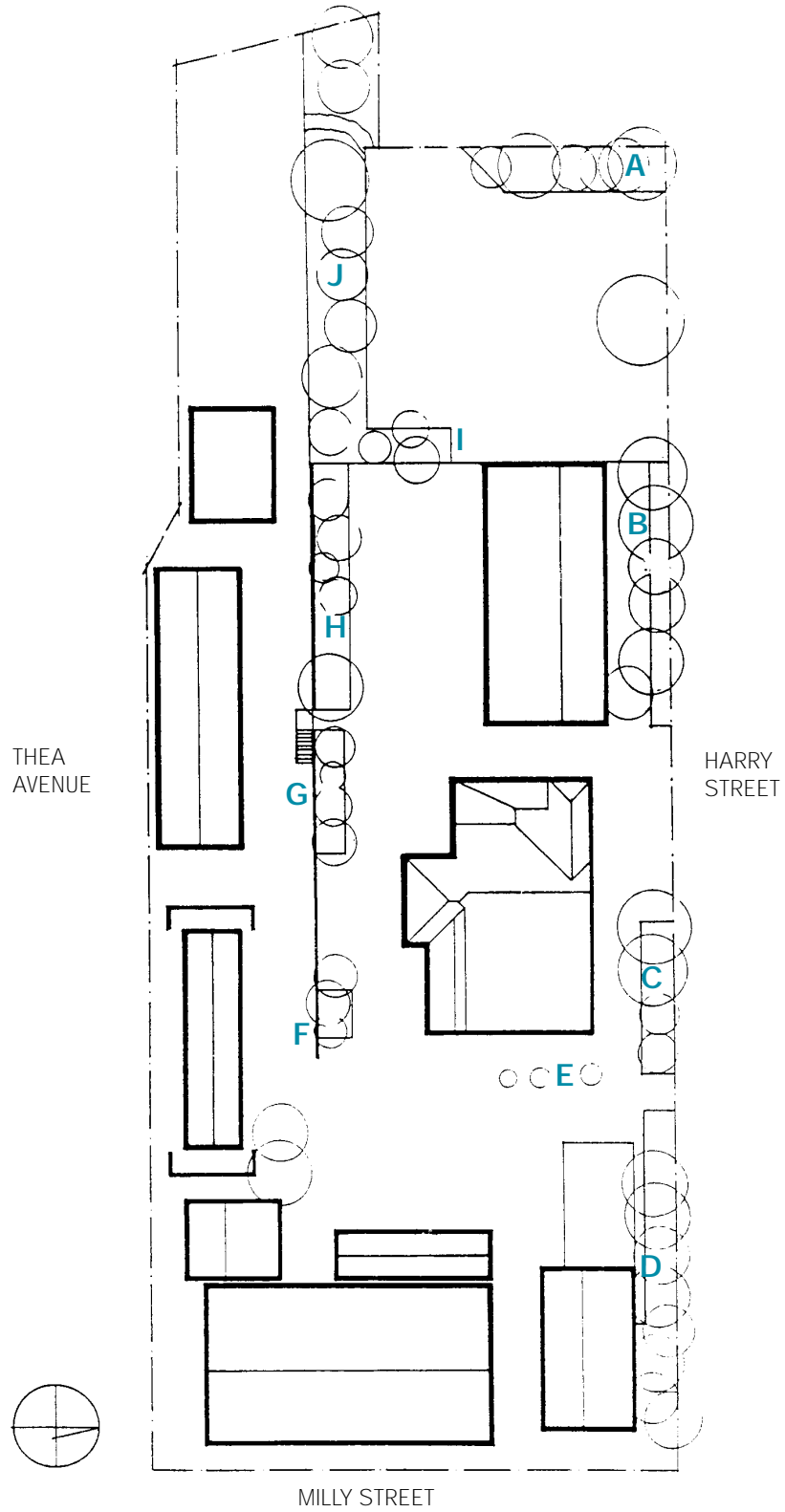

site plan

Sections of the playground are out-of-bounds to children. These areas comprise narrow spaces behind buildings and space under the demountable buildings. It is not considered that these areas provide opportunities for additional shade as no change in playground management is likely to make their use acceptable. Accordingly, these areas have been excluded from calculations.

The balance of the playground comprises four open sports areas, where cricket, handball and team games are played. Any shade structure that required the construction of columns within these areas would be inappropriate.

## Assessment

The solar protection offered by the site was assessed by preparation of shade diagrams and calculation of both shaded and unshaded areas. Existing summer and winter shade are considered, with noon summer and winter shade shown on pages 180 and 181 respectively.

The critical protection time has been selected at 1pm on 27 November, when children are required to sit to eat their lunch in the playground. At this time, 330 children must share the available shade. Given that it takes only 11 minutes to exceed maximum UVB exposure levels at this time of year, solar protection is essential.

## Quantity of shade

Analysis of existing summer shade at the site (see Table 1) shows useable shaded area per child of 2.09 m<sup>2</sup>, compared to a preferred minimum of 2.5 m<sup>2</sup>.

The quantity of shade is 135 m<sup>2</sup> less than that recommended for a school of 330 children.

**Table 1: Area and shade data**

critical protection time	1pm on 27 Nov
total playground area	2945 m <sup>2</sup>
total shaded area	1000 m <sup>2</sup>
useable shaded area	690 m <sup>2</sup>
percent playground with useable shade	24 %
percent shade useable	69 %
useable shade area per child	2.09 m <sup>2</sup> approx
recommended minimum area per child	2.50 m <sup>2</sup>
additional shade recommended	135 m <sup>2</sup>

## Sources of shade

The playground receives shade from four sources: school buildings, the new shelter, verandahs and vegetation.

Though not extensive, shade cast by the buildings is of good quality, with the east/west orientation of buildings creating shade at the critical solar noon period. The new shelter adjacent to the hall, the hall verandah and the verandah of the two storey building, all provide good solar protection.

Shade trees provide the balance of the existing shade. Their type and shade quality, which varies according to the nature of the foliage, are set out in Table 2 on page 182–3.

Sample audit

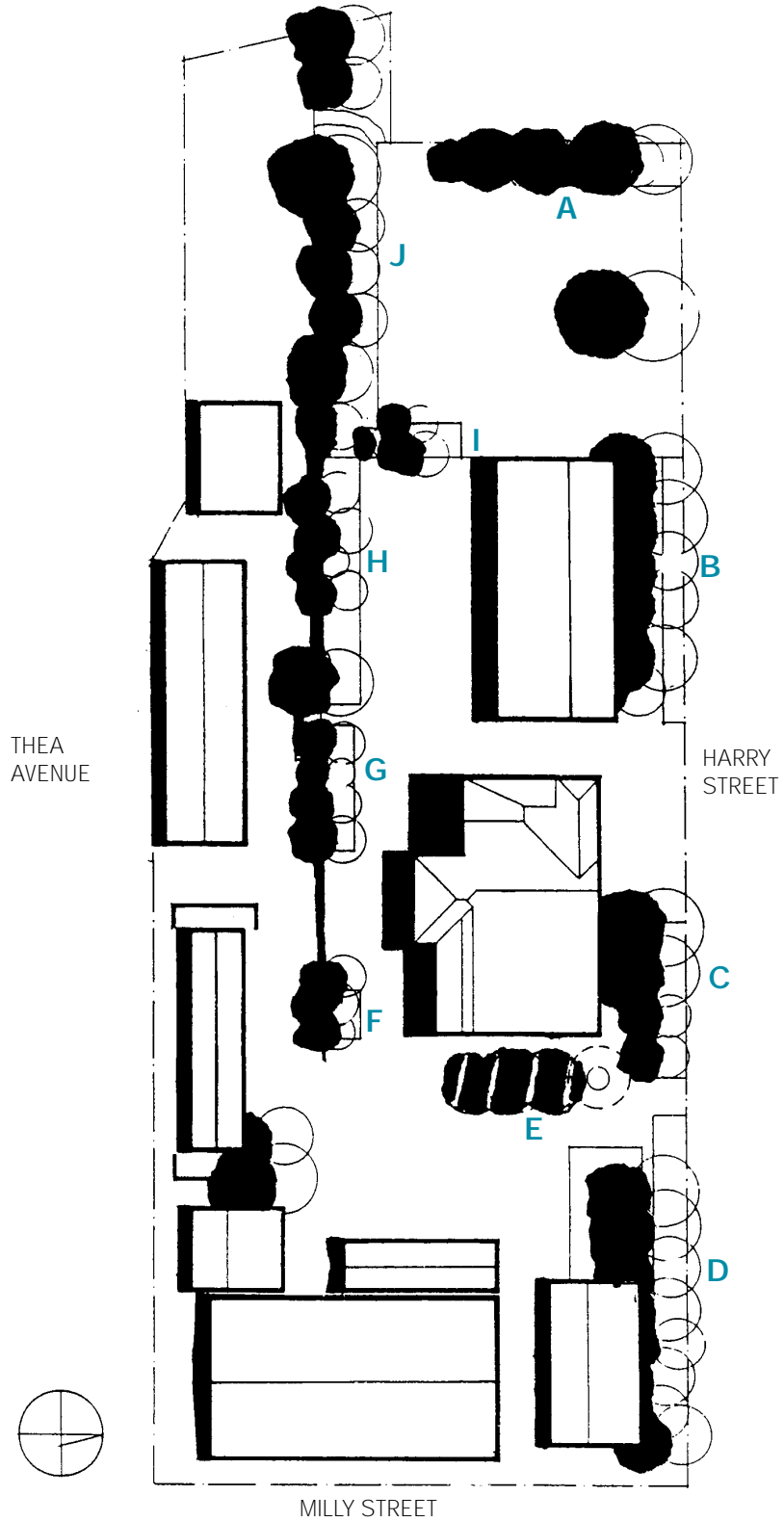

summer shade

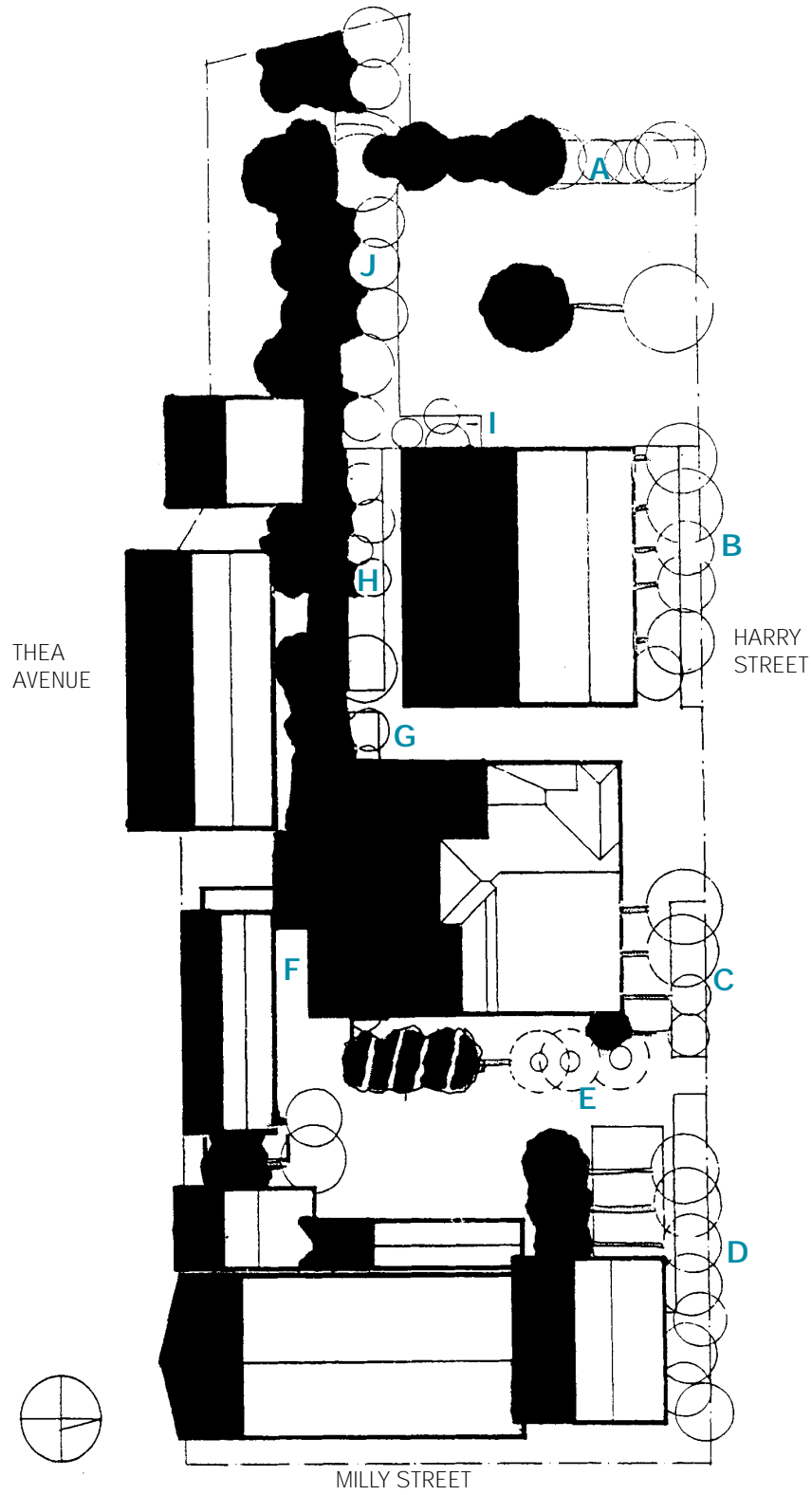

winter shade

## Sample audit

### Useability of shade

Of the available shade, there is considerable variety in its useability. As previously noted, shaded areas are currently inadequate to allow all children to eat lunch in the shade. Seating in some locations is well shaded; other seats have no shade.

Access to shaded gardens is obstructed by low vegetation, preventing full usage of shade in some areas.

The play structure, a critical area for shade, enjoys moderate protection. However, areas where active sport is played are poorly shaded in summer, due in part to the need to retain unobstructed playing areas. As children spend many hours in these areas, some form of summer shade would be beneficial, though careful consideration of the need for winter warmth is required.

**Table 2: Schedule of shade trees**

area	comments about area	species (E)–evergreen (D)–deciduous	comments about species (condition good unless noted)
A	Six canopy trees of good height and width, with shrub understorey	<i>Allocasurina torulosa</i> (E) <i>Eucalyptus robusta</i> (E) <i>Acacia floribunda</i> (E) <i>Eucalyptus maculata</i> (E) <i>Banksia integrifolia</i> (E) <i>Eucalyptus</i> species 3 <i>Eucalyptus</i> species <i>Tristania laurina</i>	
B	Soil compaction is a problem in this area. New 100x50mm timber edge, 2m from boundary, with heavy mulch and fertilizer would help.	<i>Eucalyptus scoparia</i> 3 <i>Eucalyptus</i> species (red bark)	Very young, medium and mature trees. Good top branching spread.
C	Four major trees with shrub understory. Very sandy soil, requiring edge, mulch and compost.	<i>Metrosideros</i> (E) <i>Eucalyptus</i> species <i>Hibiscus tiliaceus</i> (E) <i>Acacia longifolia</i> (E) <i>Harpephyllum kaffrum</i> (E)	Canopy very open and sparse. Near end of its life cycle. Will mature to 8m high x 8m wide.

area	comments about area	species (E)–evergreen (D)–deciduous	comments about species (condition good unless noted)
D		5 <i>Eucalyptus eximia</i> <i>Hibiscus tiliceus</i> (E) <i>Melaleuca armillaris</i> (E) <i>Acacia longifolia</i> (E) <i>Callistemon</i> species	Past its prime. Extensive planting of young specimens.
E		3 <i>Eucalyptus</i> species <i>Tristania laurina</i>	Recent planting – will mature to 10m x 4m. Recent planting – will mature to 5m x 3m. 4 – 5 years before shade-producing.
F	Damaged top foliage of <i>Eucalyptus</i> possibly due to salt burn – replace with more suitable species.	<i>Eucalyptus scoparia</i> <i>Grevillia</i> species (E) <i>Callistemon</i> “Captain Cook”	Will mature to 10m x 8m.
G	Add mushroom compost and mulch to soil.	<i>Eucalyptus maculata</i> <i>Eucalyptus</i> species <i>Hakea salificola</i> <i>Banksia integrifolia</i> <i>Leptospermum laevigatum</i>	Good canopy.
H	Overgrown with Kikuyu.	<i>Phoenix canariensis</i> (E) <i>Agonis flexuosa</i> (E) Mulberry (D)	
I		<i>Eucalyptus robusta</i> (Swamp mahogany) <i>Acacia floribunda</i> (E) <i>Acacia longifolia</i> (E)	Prone to drop limbs – not recommended. Very sparse canopy – requires more water.
J		<i>Eucalyptus nicholii</i> <i>Agonis</i> species <i>Eucalyptus</i> species (white bark)	Bank covered with copse of low <i>Agonis</i> . Multi branching, canopy sparse.

## Recommendations

It is clear that the school is already implementing a solar protection strategy. Students, staff and parents are increasingly aware of the dangers of sun exposure and, due to this awareness, a satisfactory outcome seems likely.

As this consultant has not been involved in sun protection planning at the school to date, it is likely that some of the measures suggested to combat sun exposure may have already been considered or be in hand.

### Goals to achieve

As a result of the inspection of the school and calculations of existing and recommended shade, it is recommended that planning for solar protection by way of shade should focus in two areas:

- *better use of existing summer shade* the easiest, cheapest and most achievable goal – that would improve summer solar protection without reducing winter sun
- *additional summer shade to playing areas* with minimal loss of winter sun.

### Methods for achieving goals

Better use of existing summer shade could be achieved by:

- relocation of seats from unshaded locations to areas with summer shade and, where possible, winter sun
- modification of garden beds at bases of trees to provide seating areas. Several areas have good shade that falls mostly onto garden beds. These areas have the potential for shaded seating and, with minimal pruning of low branches, could be utilised

- the garden area designated as J could become a shaded adventure play area by trimming the low branches of the *Agonis* and creating a tunnel maze. As play in this area is likely to be very attractive to children, it offers solar protection for long periods of playground use
- additional summer shade to the playing area between garden H and the 'new' two storey building would be beneficial, as this area is intensively used.

Comprising some 240 m<sup>2</sup>, this would provide a substantial shaded area for play and outdoor educational activities and exceed the additional area recommended in Table 1. An additional factor in favour of shading this area rather than others, is that the area is hard paved, so creation of shade will not be detrimental to lawn growth.

Any structure needs to be planned so as to permit games to continue free from obstruction by columns and support structures:

- A series of low tensile shade sails could provide shade without interference to the playing area below. Use the existing building as one line of support and span the sails across the area to a row of poles at the edge of garden H
- in order that winter sun to garden H is retained, the sails could be removed during the winter months. Being a low tensile structure, removal and re-erection would be easily achieved using voluntary parent labour
- sail fabric should provide at least 94 percent protection from direct UVR; a range of suitable fabrics, in a variety of colours, is available. If well-designed, these sail elements would make a positive and exciting aesthetic contribution to the school grounds.

Such a structure could be erected for some \$A8,000–\$A10,000.

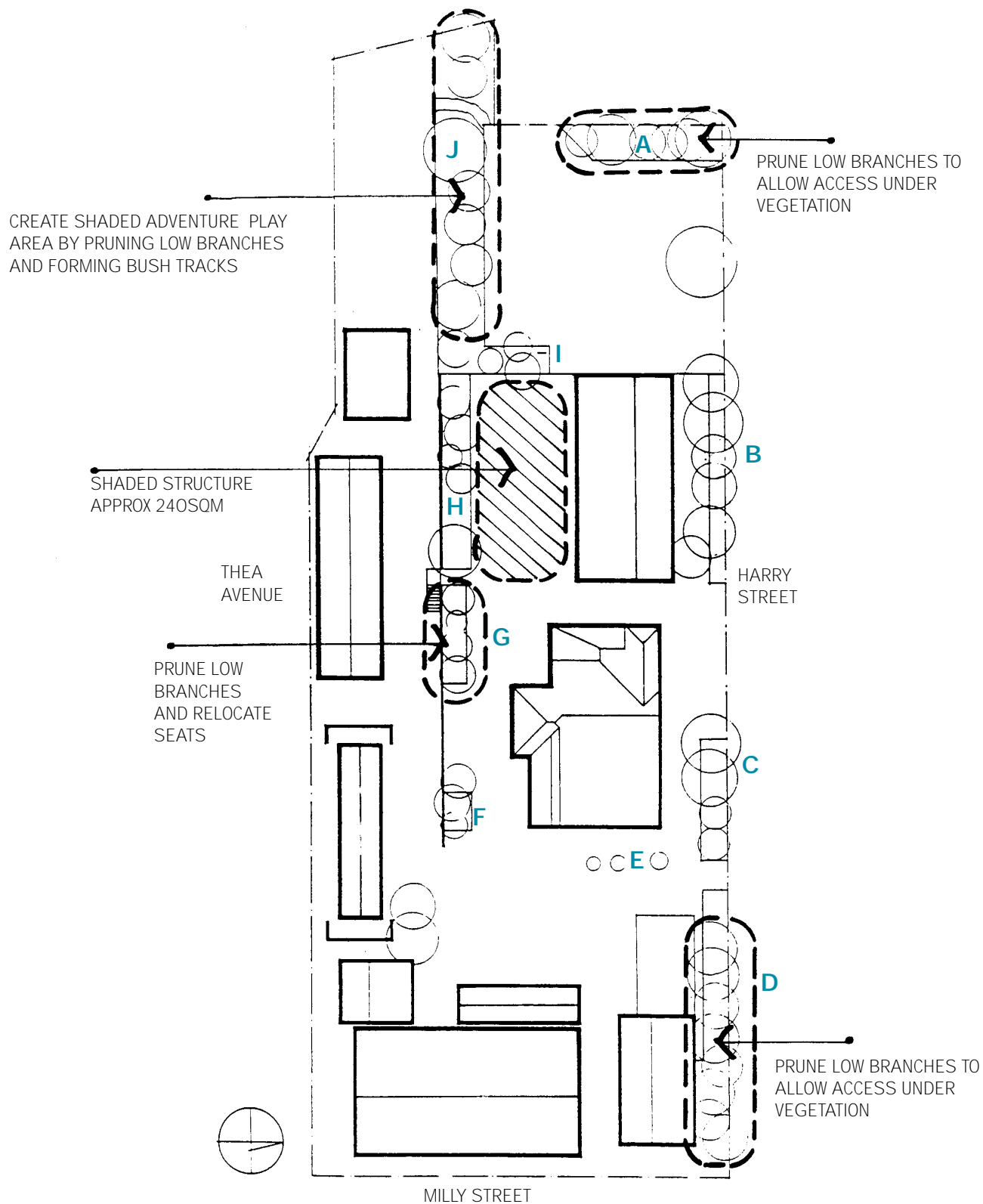

shade plan

# References

---

- Alexander-Gabrielson M. *Swimming pools – A guide to their planning, design and operation*. Illinois: Human Kinetics Publishers Inc, 1987.
- Armstrong BK. The human health consequences of ozone depletion – An overview. *Australian Meteorological Magazine* 1997;46.
- AS/NZS 4399:1996 *Sun protective clothing – Evaluation and classification*. Standards Australia and Standards New Zealand.
- AS/NZS 4422:1996 *Playground surfacing – Specifications, requirements and test methods*. Standards Australia and Standards New Zealand.
- AS/NZS 4486:1997 *Playgrounds and playground equipment Part 1 – Development, installation, inspection, maintenance and operation*. Standards Australia and Standards New Zealand.
- Australian Institute of Health and Welfare. Unpublished data. Canberra, 1997.
- Australian Radiation Laboratory – *UVR Data Net* October 1995;3.
- Ballinger JA, Prasad DK, Rudder D. *Energy efficient Australian housing*. Canberra: Australian Government Printing Service, 1992.
- Brisbane City Council, Department of Recreation and Health. Tender documents for supply and delivery of shade structures (unpublished). 1993.
- Cancer Society of New Zealand. The costs of skin cancer to New Zealand. *Cancer Update in Practice*. Issue 2, 2000
- Cancer Society of New Zealand. *Sample Sun Smart policies for primary/secondary schools*. Wellington, 2000.
- Cave, Yvonne and Valda Paddison. *The gardeners encyclopaedia of New Zealand native plants*. Auckland: Random House, 1999.
- Corkery L. *Playspace – Handbook for outdoor play environments*. Surry Hills: Community Activities Network, 1987.
- Davis BT. Shade roof systems for open deck car parks, playgrounds and similar areas. Paper presented to Membrane Structures Association of Australasia Conference; Auckland, New Zealand, July 1–2 1993.
- Diffey BL. Ultraviolet radiation in medicine. *Medical physics handbooks* 11. Bristol: Adam Hilger Ltd, 1992.
- ECVC Working Party. *Plan it! Guidelines for planning early childhood outdoor supervised play environments in New South Wales*. Kidsafe NSW, 1996.
- Elder A. *A handbook of building enclosure*. London: The Architectural Press, 1974.
- Gies PH. Letter to Australian Radiation Laboratory clients. October 1996.
- Gies PH, Roy CR and Elliot G. Ultraviolet radiation protection factors for personal protection in both occupational and recreational situations. *Radiation Protection in Australia* 1992;10:3.
- Gies PH, Roy CR, Toomey S and McLennan A. Protection Against Solar UV Radiation. Sun Protection Seminar Papers. Australian Cancer Society, 1997.
- Groves G. *Sunburn, suntan and sunscreens*. Australian Cancer Society, 1981.
- Iqbal M. *An introduction to solar radiation*. Academic Press, Don Mills, 1983.
- Koenigsberger OH and Ingersol TG. *Manual of tropical housing and building – Part 1 Climatic design*. New York: Longman Inc, 1974.
- McKenzie RL. Application of a simple model to calculate latitudinal and hemispheric differences in ultraviolet radiation. *Weather and Climate* 1991;11.
- McKenzie et al. Increased summertime UV observed in New Zealand in response to ozone loss. *Science* 285, 1709–11, 1999.
- Minnery J. A report on B.B.C swimming pools (unpublished report). Brisbane: Q Search, Queensland Institute of Technology (now Queensland University of Technology), 1988.
- New South Wales Cancer Council. Review of shade materials (unpublished).
- New South Wales Department of Community Services. *Best practice guidelines in early childhood physical environments*. Sydney, 1996, 91.
- New South Wales Department of Community Services. *Design and planning – Checklist for a new child care centre in New South Wales*. Sydney, 1996.
- New South Wales Department of Education and Training. *Sun shade in schools*. Sydney, 1998.
- New South Wales Department of Education and Training. *Protection from the Sun – Guidelines to assist in implementing the Student Welfare Policy*. Sydney, 1997.

- New South Wales Department of Education and Training. Student Welfare: Protection from the Sun Memorandum 97/152 (S.144). May 1997.
- New Zealand Health Information Service. *Mortality and demographic data*, Wellington: Ministry of Health, 2000.
- Oakman H. *Tropical and subtropical gardening*. Milton: The Jacaranda Press, 1981.
- OSH. *Guidance notes for the protection of workers from solar ultraviolet radiation*. Occupational Safety and Health Service New Zealand, Wellington, 1994.
- OSH. *Learn the basic steps to make your workplace safer*. Occupational Safety and Health Service New Zealand, Wellington, 1999.
- OSH. *What you need to know about temperature in places of work*. Occupational Safety and Health Service New Zealand, Wellington, 1997.
- Palmer, Stanley J. *Palmer's Manual of Trees, Shrubs and Climbers*. Queensland: Lancewood Publishing, 1994.
- Parsons P et al. The shady side of solar protection. *Medical Journal of Australia* 6 April 1998;168.
- Phillips RO. *Sunshine and shade in Australia*. Commonwealth Scientific and Industrial Research Organisation (CSIRO), 1992.
- Queensland Health and Department of Architecture, Queensland University. *Shade for young children*. Brisbane, 1997.
- Queensland Health and Department of Architecture, Queensland University. *Shade for sports fields*. Brisbane, 1995.
- Queensland Health and Department of Architecture, Queensland University. *Shade for public pools*. Brisbane, 1996.
- Roy CR, Gies HP and Elliott G. Solar ultraviolet radiation: Personal exposure and protection. *Journal of Occupational Health and Safety* 1998;4:2.
- Skinner C. Personal communication to John Greenwood. Bureau of Meteorology, National Climate Centre, 1996.
- Sliney DH. Physical factors in cataractogenesis: ambient ultraviolet radiation and temperature. *Investigative Ophthalmology and Visual Science* 1986;27:5.
- Sliney DH and Wolbarsht ML. *Safety with lasers and other optical sources*. New York: Plenum Press, 1980.
- South Australia Community Health Research Unit. *Planning healthy communities – A guide to doing community needs assessment*. Adelaide: Flinders Press, 1991.
- Stroud Foster J. *Mitchell's advanced building construction – The structure*. London: BT Batsford Ltd, 1963.
- Szokolay SV. *Climate, comfort and energy – Design of houses for Queensland climates*. Brisbane: The Architectural Science Unit, The University of Queensland, 1991.
- The Royal Society of New Zealand. *UV radiation and its effects*, The Royal Society of New Zealand, 1997.
- UNEP. *Environmental effects of ozone depletion 1991 Update*. United Nations Environment Programme, Nairobi, Kenya, 1991.
- Walsh P. *Early childhood playgrounds – Planning an outside learning environment*. Alberts Park: Robert Andersen and Associates, 1988.
- Yates New Zealand Ltd. *Yates Garden Guide*. New Zealand: Yates NZ Ltd, 1994.

# Glossary

---

biodegradable	capable of being decomposed by bacteria or other living organisms
critical protection time	time/s of day and year when protection from solar UVR is most important at a site
custom made structures	built shade structures that are designed specifically for a site
design brief	documents the issues that need to be considered during the design stage of the shade project
direct UVR	UVR which reaches the earth from the sun in a straight line through the atmosphere
discretionary use areas	areas of a site where people make a choice to be there, eg grassed spectator areas at sports grounds
down-cycling	tendency for recycled materials to be used in lower grade applications than the initial use
ecologically sustainable design	relational approach to design in which possible negative environmental impacts of a proposed design are minimised
embodied energy	sum of all energy used to produce a material, product or structure including extraction and processing of raw materials, manufacturing, assembly and transportation.
Environmental UVR protection strategies	seek to create outdoor spaces that provide protection from both direct and indirect UVR
equinox	times of the year when day and night are of equal length, ie 21 March and 23 September
indirect UVR	UVR which reaches the earth from any direction after being scattered by atmospheric particles or clouds and/or reflected off surfaces and terrains
macroclimate	prevailing climatic conditions
magnetic north	the direction of north as indicated by compass readings; not to be used for shadow projections
microclimate	local climatic conditions
minimal erythemal dose (MED)	amount of exposure to UVR required to produce the first detectable reddening of the skin
non-discretionary use areas	areas of a site where people are compelled to be, eg numbered seating in grandstands at sports grounds
non-renewable resource	resource that is concentrated or formed at a rate much slower than its rate of consumption, so for all practical purposes it is non-renewable
observation method	method of assessing existing shade at a site by marking the shade patterns on the ground, measuring them and plotting them to scale

off-the-shelf structures	built shade structures that are pre-manufactured
projection method	method of assessing existing shade at a site by projecting the shade patterns using sun angles and plotting them to scale
recycling	to treat a material so that new products can be manufactured from it. The main benefit of recycling is that it helps stem the flow of waste to landfill. However, recycling is not always automatically environmentally beneficial. It consumes large amounts of energy, and can disperse poisons into the environment
renewable resource	ability of a resource to be produced as part of its natural functioning system at rates comparable with its consumption
Shade Audit	procedure for determining the adequacy of existing shade at a site and whether there is a need for more shade
Shade Inventory	procedure for prioritising the provision of shade across multiple sites or for large sites with a number of precincts
solar azimuth angle	angle of the sun, measured clockwise from north in a horizontal plane
solar altitude angle	angle between the sun and the horizon at a given latitude
solar noon	time of day when the sun is highest in the sky. In summer this occurs at about 1.30pm New Zealand daylight saving time
solar UVR	part of the spectrum of electromagnetic radiation emitted by the sun, comprising UVA, UVB and UVC; cannot be seen or felt
Solar UV Index	a measure of the intensity of UVR – information supplied by NIWA
solstice	times of year when the sun is furthest from the equator, ie the 21 June, the day with the shortest period of daylight and the 22 December, the day with the longest period of daylight
stratospheric ozone	gas present in the earth's upper atmosphere, that absorbs most of the solar UVR entering the atmosphere before it reaches the earth's surface
summer protective shade	shade that minimises UVR levels, as well as reduces heat and light
thermal mass	sum of all materials used that are able to store and discharge heat (usually walls, floors and thick slabs). The greater the density of a material, the greater the thermal mass

true north	direction of north when magnetic variation is corrected. Magnetic variation differs according to location and should be determined by consulting a surveyor or referring to navigational charts. The azimuth angle at solar noon is always true north, expressed as 0 degrees
ultraviolet protection factor (UPF)	scale developed by the Australian Radiation Laboratory to rate the UVR protection provided by materials. A material's UPF rating is based on the percentage of UVR transmitted through the material
UVR protective shade	shade that minimises exposure to both direct UVR and indirect UVR
UVR reflectance	degree to which a surface material or terrain can reflect UVR
winter protective shade	shade that minimises UVR levels, while allowing for the transmission of sufficient levels of heat and light.



